

Office Linear Smart Dimming Power Supply (Constant Current Type)

- Slim metal housing;
- Overall design complies with Zhaga standards: built-in models meet Zhaga Book 13 and Book 24 specifications, while standalone models meet Zhaga Book 24 requirements;
- Supports 0-10V, PUSH DIM, and corridor lighting dimming;
- Supports NFC rapid programming, enabling smartphone app control via NFC to adjust output current, dimming modes, and other parameters for driver data interaction;
- NFC current setting with step increments as low as 1mA for enhanced compatibility and precision;
- Ultra-low 0-10V port consumption <0.05mA;
- T-PWM ultra-deep dimming technology achieving 0.01% dimming depth;
- 0-100% full-range dimming with zero visible flicker, meeting high-frequency exemption standards;
- Features soft-start gradual brightening for enhanced visual comfort;
- EU ERP compliance: no-load power consumption and network standby power <0.5W;
- 0V output at no load to prevent LED fixture damage from poor contact;
- Over-temperature, over-voltage, overload, and short-circuit protection with automatic recovery;
- Suitable for indoor Class I, II, and III luminaires, such as linear lights, triple-proof lights, floor lamps, bracket lights, and other linear or ultra-thin fixtures;
- Lifespan up to 100,000 hours under normal use;
- 5-year warranty.

5 in 1 Dimming

0-10V
1-10V
10V PWM
RX
PUSH DIM



Flicker Free

IEEE 1789

T-PWM
Dimming Technology



Dimmable:
1: 10000



The certification icon represents undergoing certification applications only, and final certification qualification subject to actual product.



Technical Specs

Model	LF-60-500-1500-G1A2 (Stand-alone)	LF-60-500-1500-G1A2 (Built-in type)		
FEATURES	Output Type	Constant current		
	Dimming Interface	0-10V(1-10V,10V PWM,RX), PUSH DIM		
	Output Feature	Isolation		
	Zhaga Standard	Book 24	Book 13,24	
	Installation Method	Can be independently installed in ceilings or light channels, etc.	Installed inside the luminaire	
	Other Features	Corridor Lighting Applications		
	IP Rating	IP20		
Insulation Class	Class II (Suitable for class I/II/III light fixtures)			
OUTPUT	Output Voltage	9-54V $\overline{=}$		
	Max. Output Voltage(No-load)	$\leq 59.5V\overline{=}$		
	Rated Current Range	500-1500mA (Set higher current levels via the mobile app's NFC feature, with step increments as low as 1mA; Default: 500mA)		
	Load Power Range	4.5-60W		
	Dimming Range	0~100%, Dimming depth: 0.01%		
	LF Current Ripple	< 5%(Maximum current for non dimming state)		
	Current Accuracy	$\pm 5\%$		
PWM Frequency	$\leq 3600\text{Hz}$			
INPUT	AC Voltage Range	220-240V \sim		
	DC Voltage Range	220-240V $\overline{=}$		
	Rated Voltage	230V \sim		
	Frequency	0/50/60Hz		
	Input Current	$\leq 0.35A/230V\sim$		
	Power Factor	PF > 0.95/230V \sim (Fully loaded)		
	THD	230V \sim @THD<10% (Fully loaded)		
	Efficiency(Typ.)	88.5%		
	Inrush Current	Cold start18A(Test twidth=123us tested under 50% Ipeak)/230V \sim		
	Anti Surge	L-N: 2KV L-FG/N-FG: 4KV		
Leakage Current	Max.0.5mA			
ENVIRONMENT	Operating Temperature	ta:-20°C~50°C tc:80°C		
	Working Humidity	20~95%RH, non-condensing		
	Storage Temperature/Humidity	-40~80°C/10~95%RH		
	Temperature Coefficient	$\pm 0.03\%/^{\circ}\text{C}(-20^{\circ}\text{C}\sim 50^{\circ}\text{C})$		
	Vibration	10~500Hz, 2G 12min/1cycle, 72 min for X, Y and Z axes respectively		
PROTECTION	Overload Protection	Automatically protect the device when the load exceeds 102% of the rated power. Automatically recover once load is reduced		
	Overheat Protection	Intelligently adjust or turn off the current output if the PCB temperature $\geq 110^{\circ}\text{C}$. When the PCB temperature <90°C, automatically recover normal output		
	Overvoltage Protection	Automatically protect the device when voltage exceeds the no-load voltage. It can be recovered automatically		
	Short Circuit Protection	Enter hiccup mode if short circuit occurs, and recover automatically		
SAFETY & EMC	Withstand Voltage	I/P-O/P: 3750V \sim /1min/ < 5mA, I/P-FG: 1750V \sim /1min/ < 5mA, O/P-FG: 500V \sim /1min/ < 5mA, Signal-FG: 500V \sim /1min/ < 5mA ①		
	Insulation Resistance	I/P-O/P: 100M Ω /500V \sim /1min/25°C/70%RH		
	Safety Certifications	CCC	China	GB19510.1, GB19510.14, GB19510.213
		TUV	Germany	EN61347-1, EN61347-2-13, EN62493
		CB	CB Member States	IEC61347-1, IEC61347-2-13
		CE	European Union	EN61347-1, EN61347-2-13, EN62384
		EAC	Russia	IEC61347-1, IEC61347-2-13
		RCM	Australia	AS 61347-1, AS 61347-2-13
	EMC Emission	ENEC	Europe	EN61347-1, EN61347-2-13, EN62384
		CCC	China	GB/T17743, GB17625.1
CE		European Union	ENIEC55015, ENIEC61000-3-2, EN61000-3-3	
EAC		Russia	IEC62493, IEC61547, EH55015	
RCM	Australia	EN55015, EN61000-3-2, EN61000-3-3, EN61547		
EMC Immunity	EN61000-4-2,3,4,5,6,8,11,EN61547			
ErP	Power Consumption	Networked standby	< 0.5W(After shutdown by command)	
		No-load power consumption	< 0.5W (When the lamp is not connected)	
	Flicker/Stroboscopic Effect	IEEE1789	Meet IEEE 1789 standard/High frequency exemption level	
	CIE SVM	PstLM ≤ 1.0 , SVM ≤ 0.4		
OTHERS	Weight(N.W.)	260g $\pm 5g$	245g $\pm 5g$	
	Dimensions	305x30.5x21.3mm(LxWxH)	280x30.5x21.3mm(LxWxH)	

①Note: When performing a withstand voltage test to ground (FG), the gas discharge tube at the drive input must be temporarily removed to prevent functional operation of the internal gas discharge tube (see IEC 60598-1-10.2). After testing is complete, it must be reinstalled to restore surge protection functionality for the power line to ground and ensure reliable contact.

Typical Current Corresponding Parameter Table

The following 21 groups of typical current data are provided for model selection reference. More currents can be set via the mobile phone APP NFC.
The settable range is 500-1500mA, and the current step value can be as low as 1mA.

LF-60-500-1500-G1A2	Output Current	500mA	550mA	600mA	650mA	700mA	750mA	800mA	850mA
	Output Voltage	9-54Vdc	9-54Vdc	9-54Vdc	9-54Vdc	9-54Vdc	9-54Vdc	9-54Vdc	9-54Vdc
	Output Power	4.5-27W	4.95-29.7W	5.4-32.4W	5.85-35.1W	6.3-37.8W	6.75-40.5W	7.2-43.2W	7.65-45.9W
	Output Current	900mA	950mA	1000mA	1050mA	1100mA	1150mA	1200mA	1250mA
	Output Voltage	9-54Vdc	9-54Vdc	9-54Vdc	9-54Vdc	9-54Vdc	9-52.5V	9-50Vdc	9-48Vdc
	Output Power	8.1-48.6W	8.55-51.3W	9-54W	9.45-56.7W	9.9-59.4W	10.35-60W	10.8-60W	11.25-60W
	Output Current	1300mA	1350mA	1400mA	1450mA	1500mA			
	Output Voltage	9-46.2Vdc	9-44.4Vdc	9-42.9Vdc	9-41.4Vdc	9-40Vdc			
	Output Power	11.7-60W	12.15-60W	12.6-60W	13.05-60W	13.5-60W			

Product Size

Unit: mm

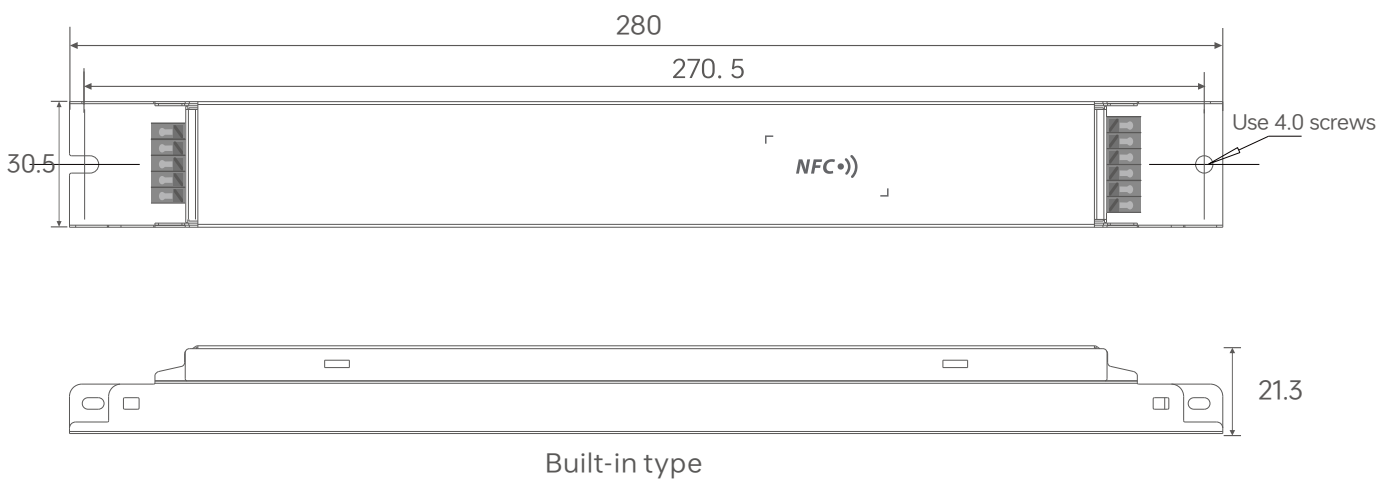
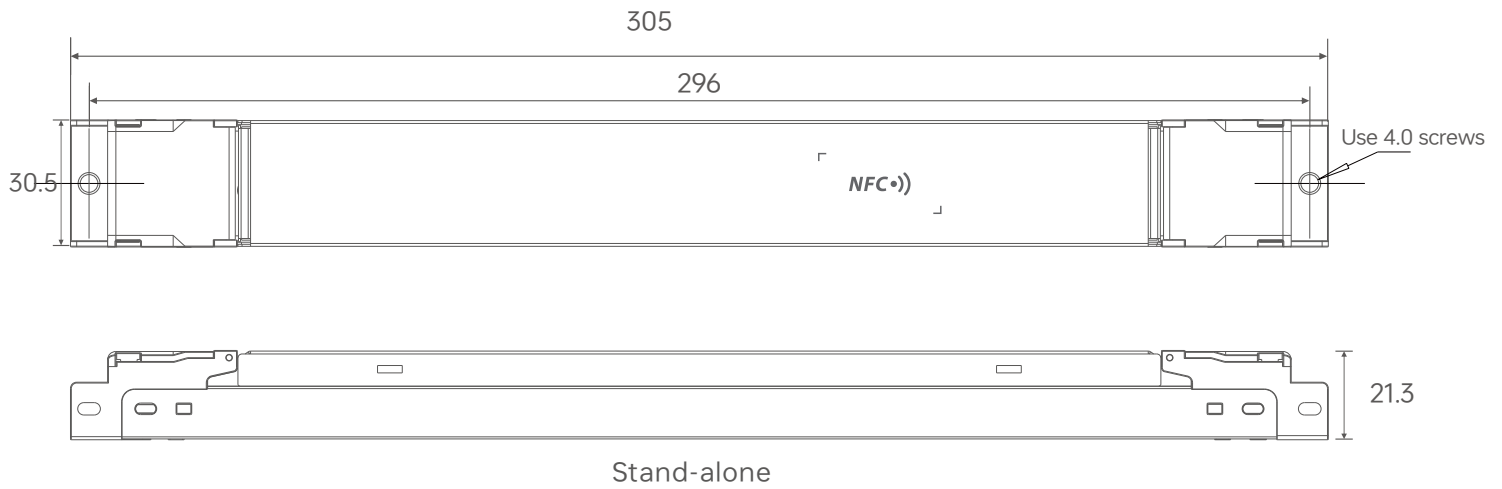

Connectivity Diagram

0-10V Connection Method

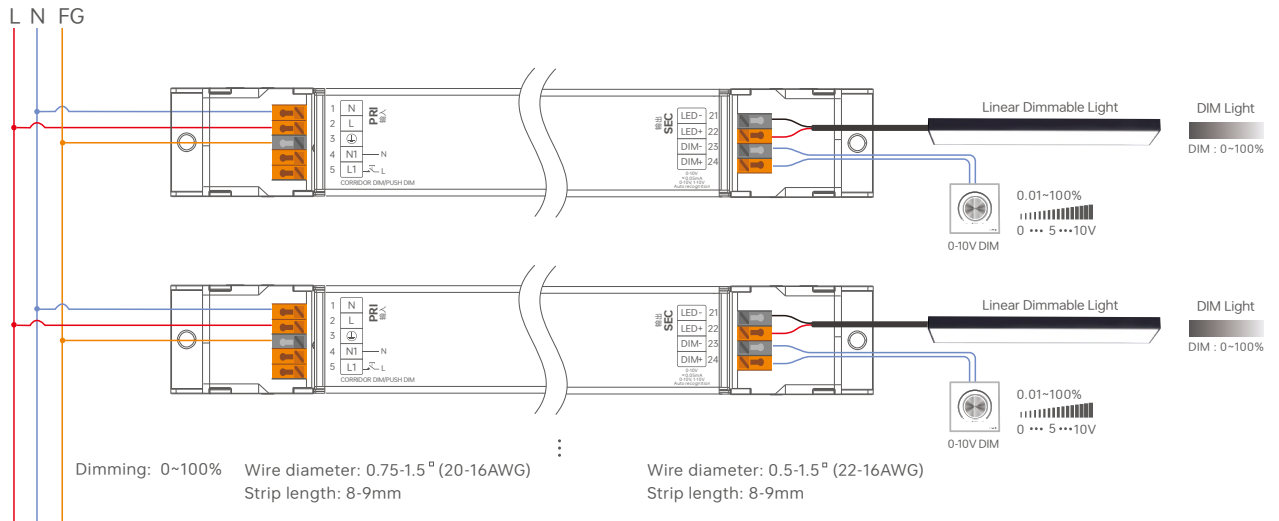

PUSH DIM Connection

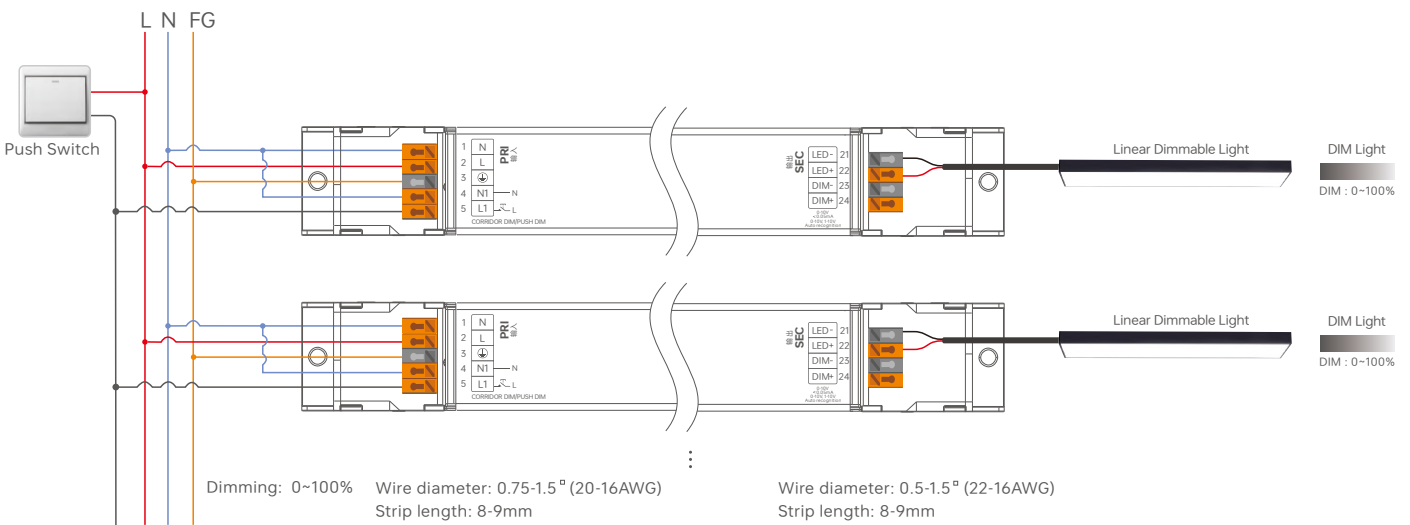

Operation Instructions

- Short press : on/off control.
- Long press: Brightness adjustment +/-, each subsequent long press will adjust the brightness in the opposite direction.
- Dimming Memory: When switched on or off again, the light will return to the previously adjusted brightness level.

Push Switch

Switch to PUSH DIM dimming mode

Method 1: If already switched to Corridor Dimming mode, connect the wiring according to the PUSH DIM wiring diagram. Reset the switch by pressing it 5 times within 3 seconds, then hold it down for 6 seconds, followed by pressing it 5 times within 3 seconds. The driver will automatically switch to PUSH DIM dimming mode.

Method 2: If already switched to Corridor Mode, you can switch to PUSH DIM dimming mode via the NFC Lighting app.

Corridor Light Mode Connection

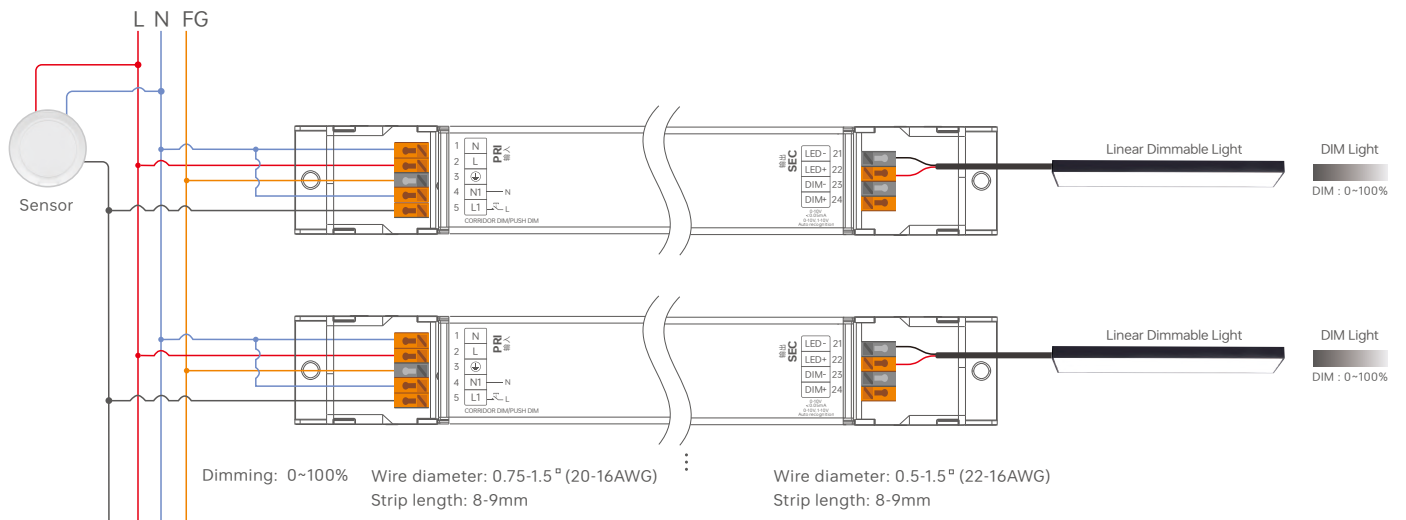

Switch to the corridor light mode

Method 1: Switch the driver to the corridor light mode via the NFC Lighting app, and the Push DIM mode will be turned off.

Method 2: After connecting the wires according to the corridor dimming wiring diagram, keep moving within the effective sensing area for more than 2 minutes, and it will automatically switch to the corridor dimming mode with all lights on at full brightness.

Method 3: After connecting the wires according to the corridor dimming wiring diagram, first replace the sensor with a common switch, then turn on the common switch and keep it conducting for 2 minutes. The driver will automatically switch to the corridor dimming mode. After that, remove the common switch and replace it with the sensor again.

Note: During normal operation, it is recommended to set the hold-time of the motion sensor to the minimum. It is necessary to select a motion sensor with an AC switch.

Process of Corridor Dimming

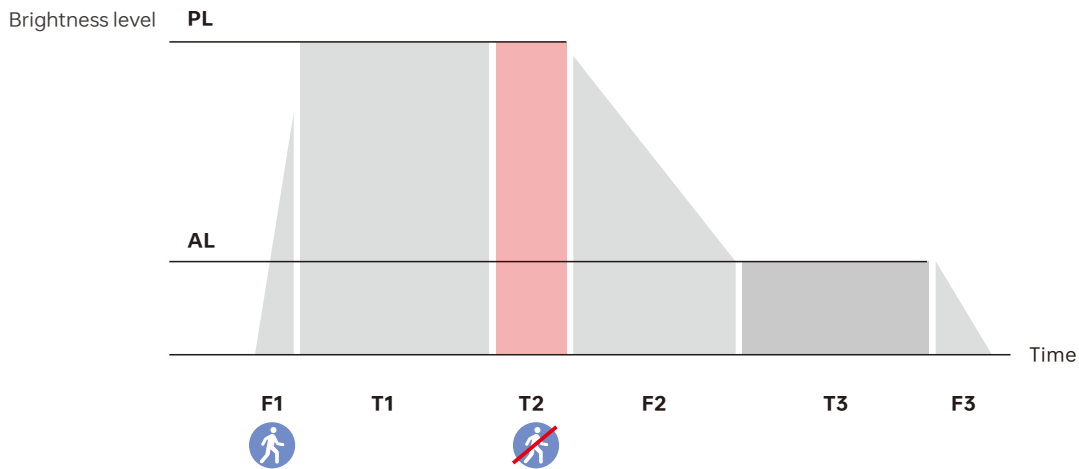

Name	Default	Setting Range
(F1) Fade-in Detection Time	1 s	0-100 s
(PL) Detection Brightness	255	0-255
(T1) Induction Hold Time	Set via the sensor	
(T2) Delay Time	30 s	0 s,5 s,10 s,20 s,30 s,45 s,1 min, 2 min, 3 min,5 min,10 min,20 min,30 min
(F2) Gradual Exit Sensing Time	1 s	0-100 s
(AL) Hold Brightness Level	100	0-255
(T3) Detection Hold Time	30 s	0 s,5 s,10 s,20 s,30 s,45 s,1 min,2 mins,3 mins,5 mins, 10 mins,20 mins,30 mins,Permanent
(F3) Fade-out Time to Off	1 s	0-100 s

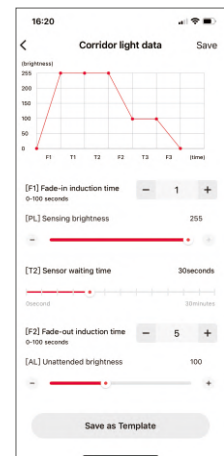

Note: *If the lamp needs to be on standby at a low brightness level, the [T3] Sensing Standby Time should be set to "Permanent".
*The above parameters are set through the NFC lighting APP.

Protective Housing Application Diagram

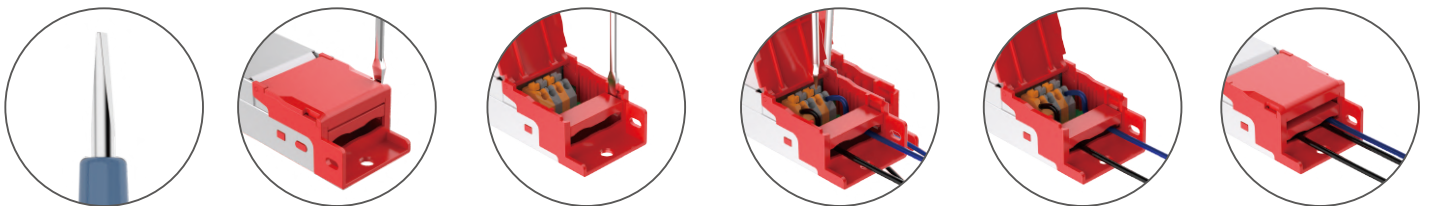

1. Prepare a screwdriver with a 0.6mm bit.
2. Use a screwdriver to pry up the protective cover on the side panel.
3. Use a screwdriver to pry up the side of the terminal block.
4. Connect the wiring according to the wiring diagram.
5. Press down on the wire board to secure the wire.
6. Close the protective cover.

Installation Precautions

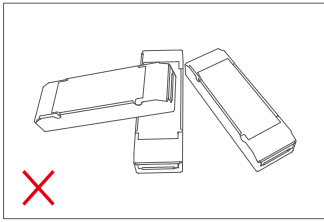

Please do not stack the products. The distance between two products should be $\geq 15\text{cm}$ so as not to affect heat dissipation or the lifetime of the products.

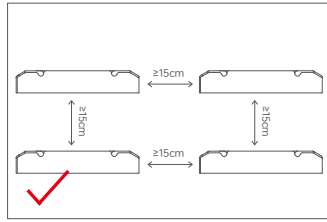

Note: Installation must comply with the product's operating temperature range. Do not install inside lighting fixtures to avoid exceeding the product's operating temperature range, which may affect its lifespan.

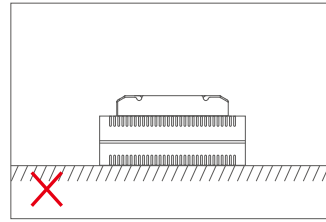

Please not place the products on power supplies. The distance between the product and the power supplies should be $\geq 15\text{cm}$ so as not to affect heat dissipation or shorten the lifetime of the products.

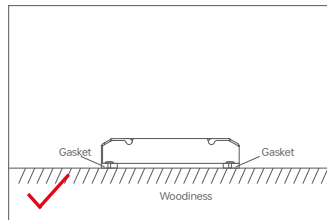
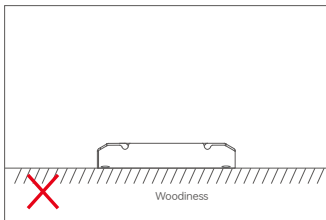
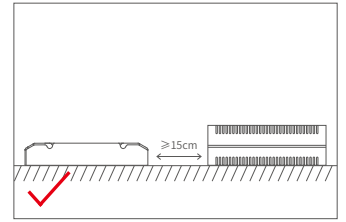

Do not fix the product screws tightly against the wooden board. Instead, add a washer with a thickness of $\geq 7\text{mm}$ under the fixing screws. Leaving some gaps can effectively dissipate heat, preventing any impact on the product's heat dissipation performance and service life.

Use the NFC Lighting APP

Scan the QR code below with your mobile phone and follow the prompts to complete the APP installation (According to performance requirements, you need to use a NFC-capable Android phone, or an iPhone 8 and later that are compatible with iOS 13 or higher).



* Before you begin setting the parameters of the driver, please make sure the driver is powered off.

Read/Write the LED driver

Use your NFC-capable phone to read LED driver data, then edit the parameters and they can be directly written to the driver.

1. Read the LED driver

On the APP home page, click **【Read/Write LED driver】**, then keep the programmer's sensing area close to the NFC sensing area of the driver to read the driver parameters.



2. Edit parameters

Click on [Parameter Management] to edit more advanced parameters such as Output Current, Select Brand, Dimming Type, Power-on Fading Time, Dimming Curve, Brightness Range and Corridor Light.

3. Write to the drive

After completing the parameter settings, click [Write] in the upper right corner, and keep the programmer's sensing area close to the NFC sensing area of the driver, so the parameters can be written to the driver.

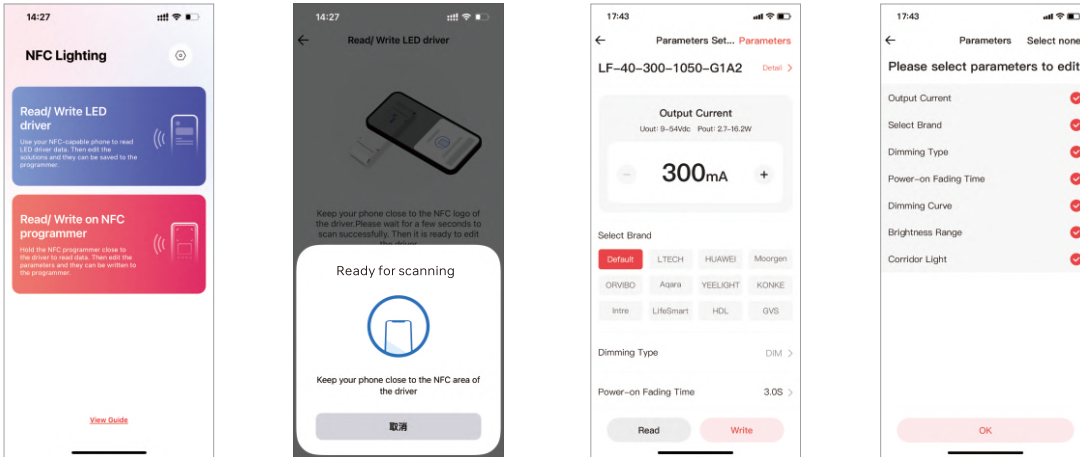

Relationship Diagrams

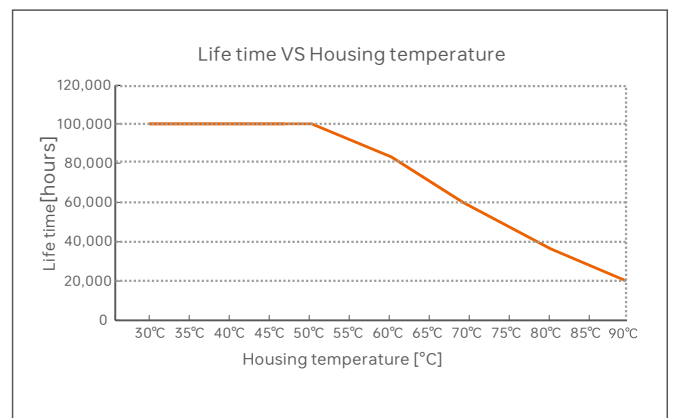
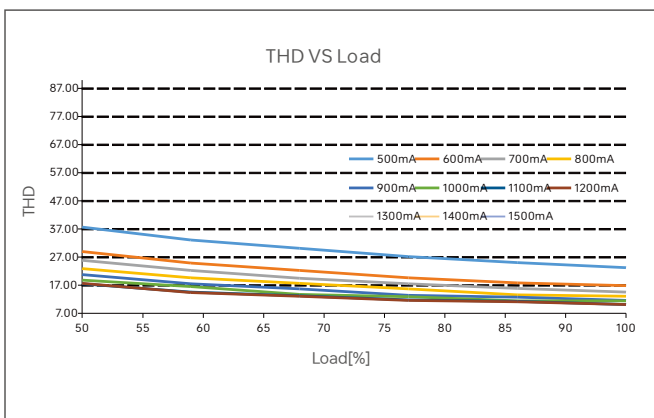
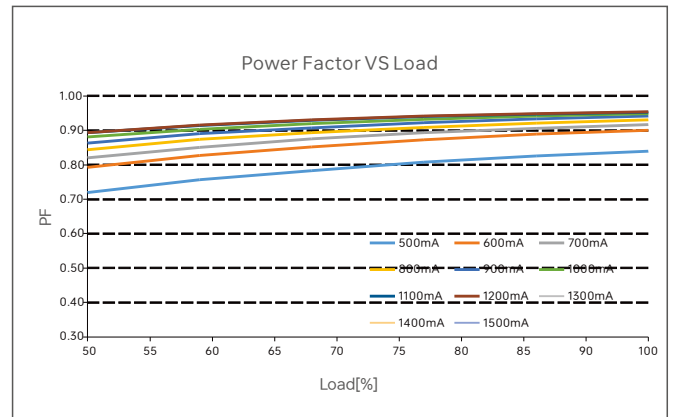
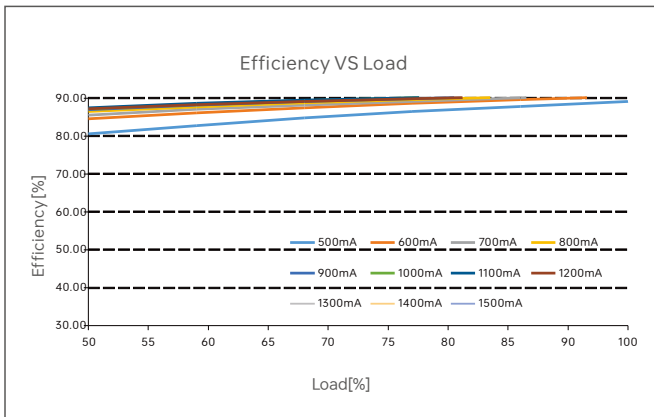

Surge Current & Corresponding Miniature Circuit Breaker (MCB) Load Capacity Table

MCB Model	B10	B13	B16	B20	B25	C10	C13	C16	C20	C25	D10	D13	D16	D20	D25
Maximum Load Capacity	15	19	24	30	40	17	22	27	35	43	20	25	31	39	49

Remarks:

1. Test Conditions: Cold start 18A(Test twidth=123us tested under 50% Ipeak)/230V ~ .
2. The number of supported drivers may vary depending on the brand and model of the MCB.
3. It is recommended not to exceed the specified load capacity during on-site installation. The actual load should be determined based on field conditions.
4. If the ambient temperature exceeds 30°C or multiple MCBs are installed side by side, the number of installed drivers must be reduced and recalculated accordingly.
5. Electricians typically use Type B MCBs for residential lighting and Type C MCBs for commercial lighting applications.
6. Different testing equipment may yield variations in measured current peaks and pulse widths. Always use professional-grade instruments for accurate testing.

Flicker Test Sheet

IEEE 1789

Limit of modulation in low risk area	
Waveform frequency of optical output	limit (%)
$f \leq 8\text{Hz}$	0.2
$8\text{Hz} < f \leq 90\text{Hz}$	$0.025 \times f$
$90\text{Hz} < f \leq 1250\text{Hz}$	$0.08 \times f$
$f > 1250\text{Hz}$	Exemption assessment
Limit of modulation in no effect area	
Waveform frequency of optical output	limit (%)
$f \leq 10\text{Hz}$	0.1
$10\text{Hz} < f \leq 90\text{Hz}$	$0.01 \times f$
$90\text{Hz} < f \leq 3125\text{Hz}$	$(0.08/2.5) \times f$
$f > 3125\text{Hz}$	Exemption assessment (High frequency exemption)

- Brightness
- ▲ 0.1%
 - ◆ 1%
 - ▲ 5%
 - ◆ 10%
 - 20%
 - ▲ 30%
 - 40%
 - ★ 50%
 - 60%
 - 70%
 - 80%
 - ★ 90%
 - ◆ 100%

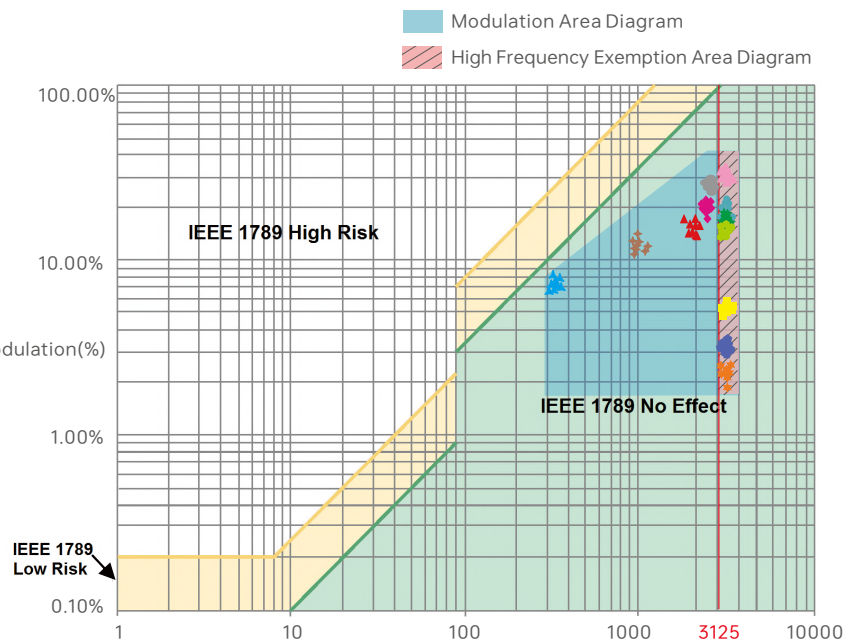

Marks in the right chart were tested results of different current ranges. The output frequency is 0Hz in 100% brightness and its corresponding modulation is 0%, which could not be shown in the right chart.

Packaging Specification

Model	LF-60-500-1500-G1A2
Packaging box size	325×255×140mm(L×W×H)

Packaging Style Drawing

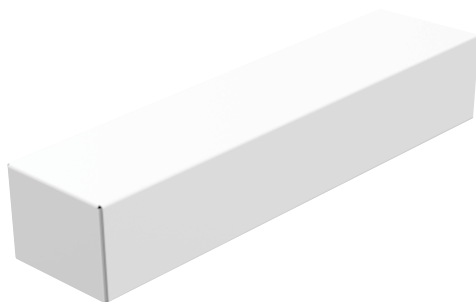

Inner packaging box



Full box packaging

Transportation and Storage

1. Transportation

Products can be shipped via vehicles, boats and planes.

During transportation, products should be protected from rain and sun. Please avoid severe shock and vibration during the loading and unloading process.

2. Storage

The storage conditions should comply with the Class I Environmental Standards. The products that have been stored for more than six months are recommended to be re-inspected and can be used only after they have been qualified.

Attentions

- Product installation and commissioning should be done by a qualified professional.
- LTECH products are and not lightningproof non-waterproof (special models excepted). Please avoid the sun and rain. When installed outdoors, please ensure they are mounted in a water proof enclosure or in an area equipped with lightning protection devices.
- Good heat dissipation will prolong the working life of products. Please ensure good ventilation.
- Please check if the working voltage used complies with the parameter requirements of products.
- The diameter of wire used must be able to load the light fixtures you connect and ensure the firm wiring.
- Before you power on products, please make sure all the wiring is correct in case of incorrect connection that causes damage to light fixtures.
- If a fault occurs, please do not attempt to fix products by yourself. If you have any question, please contact your suppliers.
- * This manual is subject to changes without further notice. Product functions depend on the goods. Please feel free to contact our official distributors if you have any question.

Warranty Agreement

- Warranty periods from the date of delivery: 5 years.
- Free repair or replacement services for quality problems are provided within warranty periods.

Warranty exclusions below:

- Beyond warranty periods.
- Any artificial damage caused by high voltage, overload, or improper operations.
- Products with severe physical damage.
- Damage caused by natural disasters and force majeure.
- Warranty labels and barcodes have been damaged.
- No any contract signed by LTECH.

1. Repair or replacement provided is the only remedy for customers. LTECH is not liable for any incidental or consequential damage unless it is within the law.
2. LTECH has the right to amend or adjust the terms of this warranty, and release in written form shall prevail.

Update Log

Version	Updated Time	Update Conten	Updated by
A0	20251111	Original version	Haipeng Li

办公线性智能调光电源 (恒流型)

- 轻薄型金属外壳;
- 整体设计符合Zhaga标准, 内置式符合Zhaga标准Book 13和Book 24的规范要求, 独立式符合Zhaga标准Book 24的规范要求;
- 支持0-10V、PUSH DIM、走廊灯调光;
- 支持NFC极速编程, 可使用手机APP通过NFC更改输出电流、调光方式等参数, 实现驱动器数据交互功能;
- NFC设置电流步进值低至1mA, 兼容性更高更精细;
- 0-10V端口超低消耗<0.05mA
- T-PWM超深度调光技术, 调光深度可达0.01%;
- 0-100%全程调光无可视频闪, 高频豁免考核级别;
- 带软启动渐亮功能, 让人眼视觉更舒服;
- 欧盟ERP空载功耗、网络待机功耗 < 0.5W;
- 空载0V输出, 防止接触不良损坏LED灯具;
- 过温、过压、过载、短路保护, 可自动恢复;
- 适合室内I、II、III类灯具, 如: 线条灯, 三防灯, 落地灯, 支架灯等线条型或超薄型灯具;
- 常规使用下寿命可达10万小时;
- 5年保修期。

5合1调光
0-10V
1-10V
10V PWM
RX
PUSH DIM

调光

T-PWM
超深度调光技术

无频闪
IEEE1789
高频豁免考核级别

Dimmable:
1: 10000



认证图标仅代表产品正在进行一系列的认证申请, 认证资质以产品实物为准。

技术参数

型号	LF-60-500-1500-G1A2 (带端盖-独立式)	LF-60-500-1500-G1A2 (不带端盖-内置式)		
特征	输出类型	恒流		
	调光接口	0-10V(1-10V,10V PWM,RX), PUSH DIM		
	输出特征	隔离		
	Zhaga标准	Book 24	Book 13,24	
	安装方式	可以独立安装于天花或灯槽内等	安装于灯具内部	
	其它功能	走廊灯应用		
	防护等级	IP20		
绝缘等级	II类(适用于室内I、II、III类灯具)			
输出	输出电压	9-54V $\overline{\text{m}}$		
	最大输出电压(空载)	$\leq 59.5V\overline{\text{m}}$		
	工作电流范围	500-1500mA (通过手机APP NFC设置更多电流, 步进值低至1mA; 默认: 500mA)		
	负载功率范围	4.5-60W		
	调光范围	0~100%, 调光深度:0.01%		
	电流纹波	< 5% (输出最大电流非调光状态)		
	电流精度	$\pm 5\%$		
PWM调光频率	$\leq 3600\text{Hz}$			
输入	交流电压范围	220-240V~		
	直流电压范围	220-240V $\overline{\text{m}}$		
	额定电压	230V~		
	频率范围	0/50/60Hz		
	输入电流	$\leq 0.35A/230V\sim$		
	功率因数	PF > 0.95/230V~(满载)		
	总谐波失真THD	230V~@THD<10% (满载)		
	效率(Typ.)	88.5%		
	浪涌电流	冷启动18A(在50%peak下测twidth=123us)@230V~		
	抗浪涌	L-N: 2KV L-FG/N-FG: 4KV		
漏电流	Max.0.5mA			
环境	工作温度	ta:-20°C~50°C tc:80°C		
	工作湿度	20~95%RH, 无冷凝		
	储存温度/湿度	-40~80°C/10~95%RH		
	温度系数	$\pm 0.03\%/^{\circ}\text{C}(-20^{\circ}\text{C}\sim 50^{\circ}\text{C})$		
	耐振动	10-500HZ, 2G 12分钟/周期, X,Y,Z轴各72分钟		
保护	过载保护	负载超过额定功率 ≥ 1.02 倍时自动保护, 减轻负载自动恢复		
	过温保护	根据PCB温度超标情况($\geq 110^{\circ}\text{C}$), 智能调节电流输出或关闭, 可自动恢复; PCB温度 < 90°C时, 可自动恢复正常输出		
	过压保护	超过空载电压值进入保护, 可自行恢复		
	短路保护	输出线路短路进入打嗝模式, 可自动恢复		
	耐压	输入对输出: 3750V~/1min/ < 5mA, 输入对地(FG): 1750V~/1min/ < 5mA, 输出对地(FG): 500V~/1min/ < 5mA, 信号对地(FG): 500V~/1min/ < 5mA ①		
安规和电磁规格	绝缘阻抗	输入对输出: 100M Ω /500V~/1min/25°C/70%RH		
	安全规范	CCC	中国	GB19510.1, GB19510.14, GB19510.213
		TUV	德国	EN61347-1, EN61347-2-13, EN62493
		CB	CB成员国	IEC61347-1, IEC61347-2-13
		CE	欧盟	EN61347-1, EN61347-2-13, EN62384
		EAC	俄罗斯	IEC61347-1, IEC61347-2-13
		RCM	澳洲	AS 61347-1, AS 61347-2-13
	电磁兼容发射	ENEC	欧洲	EN61347-1, EN61347-2-13, EN62384
		CCC	中国	GB/T17743, GB17625.1
		CE	欧盟	ENIEC55015, ENIEC61000-3-2, EN61000-3-3
EAC		俄罗斯	IEC62493, IEC61547, EH55015	
电磁兼容抗扰度	RCM	澳洲	EN55015, EN61000-3-2, EN61000-3-3, EN61547	
	EN61000-4-2,3,4,5,6,8,11,EN61547			
ErP	功耗	网络待机功耗	< 0.5W (通过指令关机后)	
		空载功耗	< 0.5W (不接灯具时)	
	频闪/频闪效应	IEEE1789	满足无影响/高频豁免考核级别	
其他	产品重量	260g \pm 5g	245g \pm 5g	
	产品尺寸	305x30.5x21.3mm(LxWxH)	280x30.5x21.3mm(LxWxH)	

①备注:当输入对地(FG)进行耐压测试时,位于驱动器输入端的气体放电管需要被临时性地移除,以防止驱动器内部的气体放电管功能性动作(参见 IEC 60598-1-10.2)。待测试完成后,必须被重新安装以恢复电力线对地的浪涌保护功能,并且确保可靠性接触。

典型电流对应参数表

下图典型21组电流数据供选型参考，均可通过手机APP NFC设置更多电流，可设置范围在500-1500mA，电流步进值低至1mA

LF-60-500-1500-G1A2	输出电流	500mA	550mA	600mA	650mA	700mA	750mA	800mA	850mA
	输出电压	9-54Vdc	9-54Vdc	9-54Vdc	9-54Vdc	9-54Vdc	9-54Vdc	9-54Vdc	9-54Vdc
	输出功率	4.5-27W	4.95-29.7W	5.4-32.4W	5.85-35.1W	6.3-37.8W	6.75-40.5W	7.2-43.2W	7.65-45.9W
	输出电流	900mA	950mA	1000mA	1050mA	1100mA	1150mA	1200mA	1250mA
	输出电压	9-54Vdc	9-54Vdc	9-54Vdc	9-54Vdc	9-54Vdc	9-52.5V	9-50Vdc	9-48Vdc
	输出功率	8.1-48.6W	8.55-51.3W	9-54W	9.45-56.7W	9.9-59.4W	10.35-60W	10.8-60W	11.25-60W
	输出电流	1300mA	1350mA	1400mA	1450mA	1500mA			
	输出电压	9-46.2Vdc	9-44.4Vdc	9-42.9Vdc	9-41.4Vdc	9-40Vdc			
	输出功率	11.7-60W	12.15-60W	12.6-60W	13.05-60W	13.5-60W			

尺寸图

单位:mm

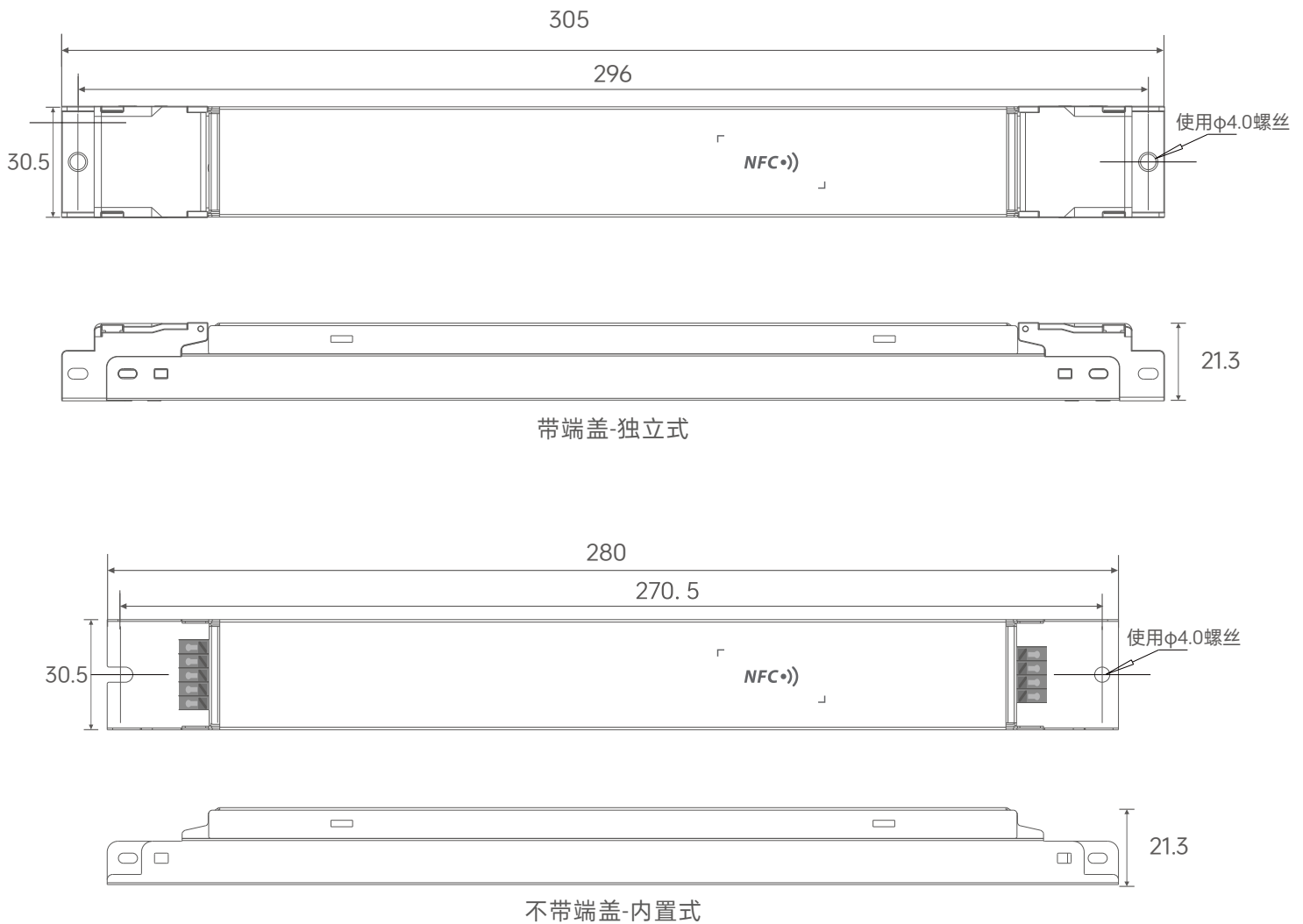

连接应用图

0-10V连接方式

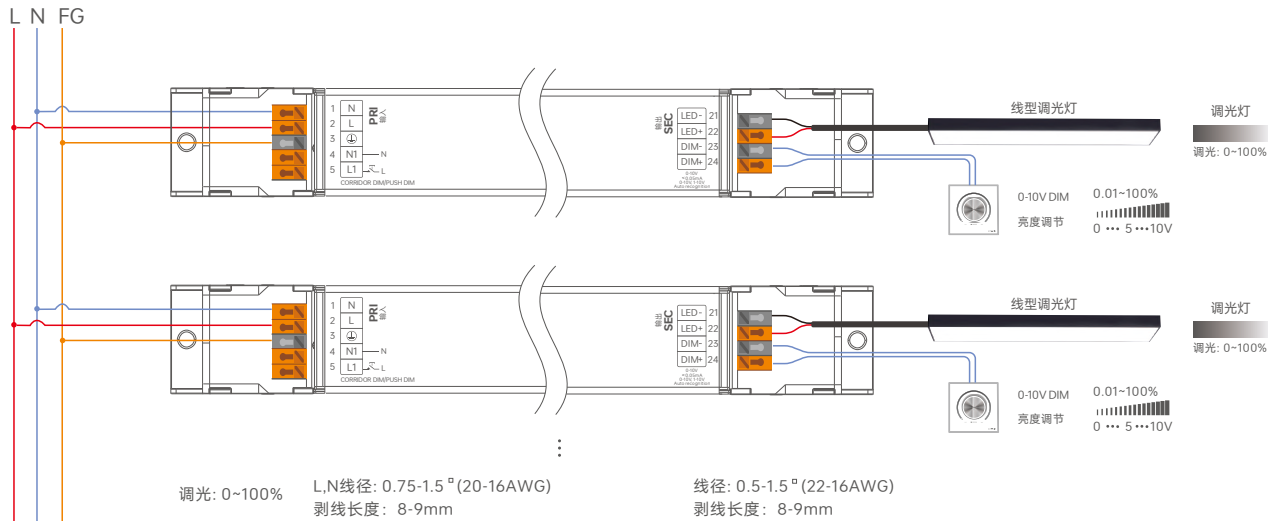

PUSH DIM连接方式

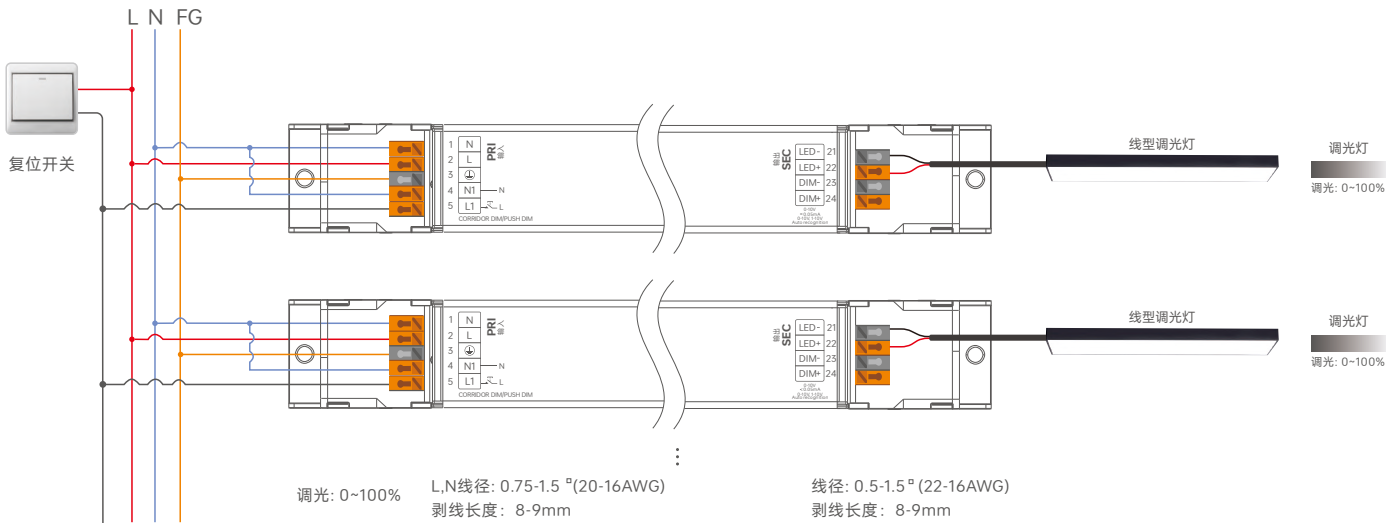

操作说明

- 短按: 开关控制。
- 长按: 亮度调节+/-, 每隔一次长按, 亮度会向相反方向调整。
- 调光记忆: 当再次开关时, 灯光会回到先前调整的亮度水平

复位开关

切换至PUSH DIM调光模式

方式 1: 若是已切换至走廊调光模式, 可以按照PUSH DIM接线图接好线路, 复位开关 3 秒内短按 5 次, 然后长按 6 秒后再 3 秒内短按 5 次, 驱动器将会自动切换至 PUSH DIM 调光模式。

方式 2: 若是已切换至走廊模式, 可以通过 NFC Lighting app 切换成 PUSH DIM 调光模式。

走廊灯连接方式

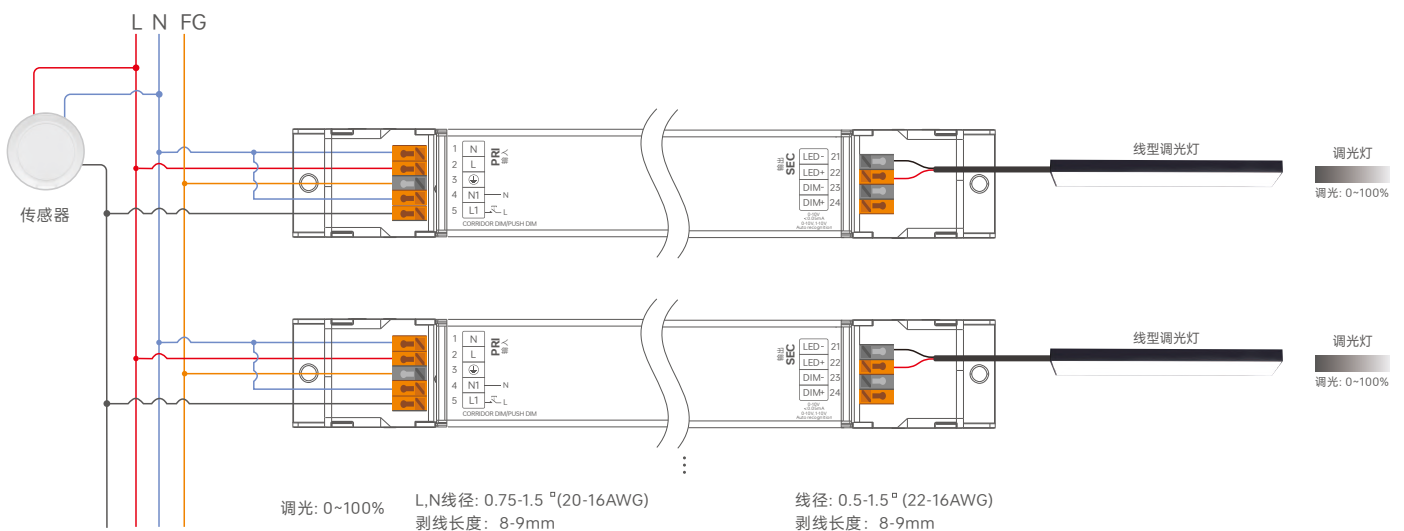

切换至走廊灯模式

方式 1: 通过NFC配置并切换走廊灯功能, PUSH DIM功能关闭。

方式 2: 按照走廊调光接线图接好线后, 保持有效感应区域内移动并持续2分钟以上, 自动切换成走廊调光模式并全亮灯。

方式 3: 按照走廊调光接线图接好线后, 先将传感器更换为普通开关, 然后打开普通开关持续导通2分钟, 驱动器将自动切换到走廊调光模式, 然后将普通开关移除并更换回传感器。

备注: 正常工作时, 推荐将移动感应器的维持时间(Hold-time)设置为最小。

需要选用带AC开关的移动感应器。

走廊调光 工作过程

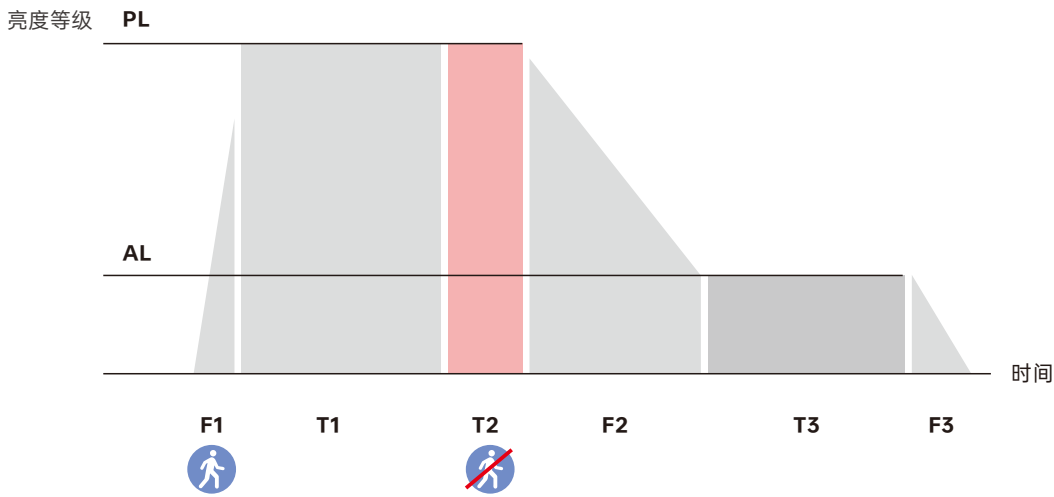

名称	默认	设置范围
(F1) 感应渐入时间	1 秒	0-100 秒
(PL) 感应亮度	255	0-255
(T1) 感应保持时间	通过传感器设置	
(T2) 感应延迟时间	30 秒	0 秒, 5 秒, 10 秒, 20 秒, 30 秒, 45 秒, 1 分钟, 2 分钟, 3 分钟, 5 分钟, 10 分钟, 20 分钟, 30 分钟
(F2) 无感应渐出时间	1 秒	0-100 秒
(AL) 无人守候亮度	100	0-255
(T3) 守候时间	30 秒	0 秒, 5 秒, 10 秒, 20 秒, 30 秒, 45 秒, 1 分钟, 2 分钟, 3 分钟, 5 分钟, 10 分钟, 20 分钟, 30 分钟, 永久
(F3) 渐出到关闭时间	1 秒	0-100 秒

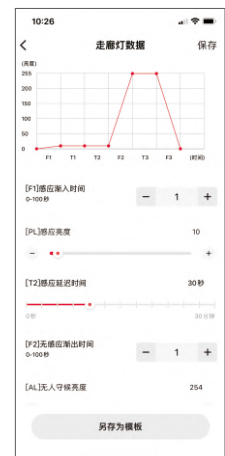

备注: *如灯需要低亮度守候, 需要设置[T3]感应守候时间为永久

*以上参数由NFC lighting APP 设置

保护盖应用图

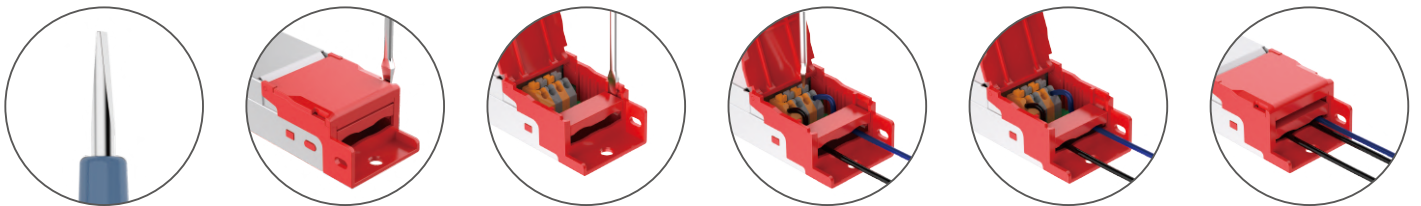

1. 准备0.6mm批头的螺丝批。
2. 在侧板使用螺丝批撬起保护盖。
3. 用螺丝批撬起压线板侧边。
4. 按照接线图所示进行接线。
5. 向下推压线板, 可固定线。
6. 合上保护盖即可。

安装注意事项

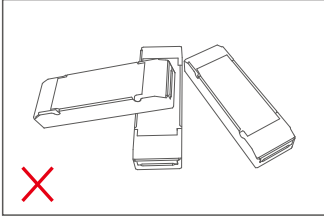

请勿将产品堆叠摆放，产品与产品间隔距离应 $\geq 15\text{cm}$ ，避免影响产品散热和使用寿命。

注：安装需符合产品的环境工作温度，切勿安装到灯具内部，以免超出产品环境工作温度影响产品寿命。

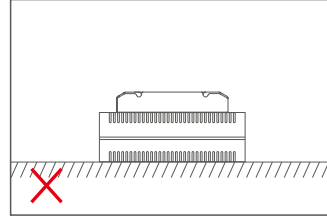
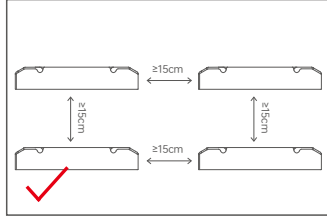

请勿将产品置于电源上方，与电源间隔距离应 $\geq 15\text{cm}$ ，避免影响产品散热而减少使用寿命。

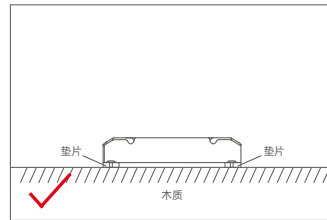
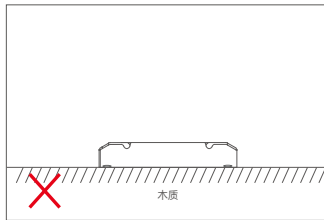
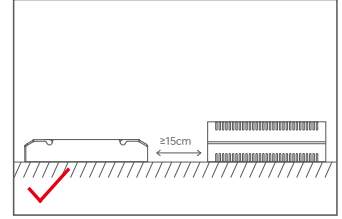

请勿将产品螺丝固定紧贴于木板，应在固定螺丝下增加 $\geq 7\text{mm}$ 的垫片，留点空隙可以有效散热，避免影响产品散热和使用寿命。

搭配 NFC Lighting APP 使用

通过手机扫描下方二维码，按提示完成APP安装。

(因性能需求，要求手机型号苹果：iPhone 8及以上、且操作系统iOS13及以上； 安卓：具备NFC功能机型)



* 设置驱动器参数时，必须在驱动器断电情况下进行操作。

读/写智能电源

使用手机，通过NFC读取驱动器信息，根据需求设置参数后，可直接写入驱动器。

1. 读取驱动器

在APP“首页”点击【读/写智能电源】，将手机感应区域靠近驱动器NFC标识点，读取驱动器参数。



2. 编辑参数

点击【参数管理】可编辑输出电流、选择品牌、调光方式、通电渐变时间、调光状态、调光曲线、亮度范围以及走廊灯等更多高级参数。

3. 写入驱动器

参数设置完成后，点击右上角【写入】，将手机感应区域靠近驱动器NFC标识点，即可写入驱动器成功修改参数。



关系图表

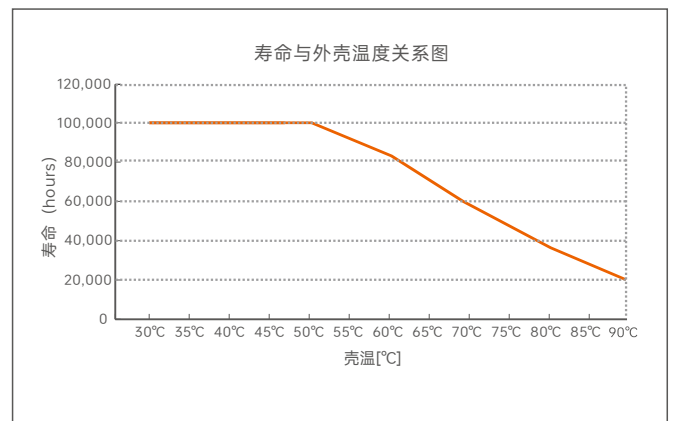
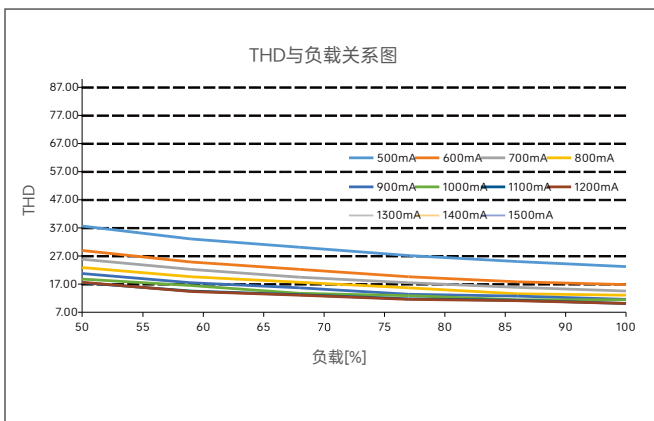
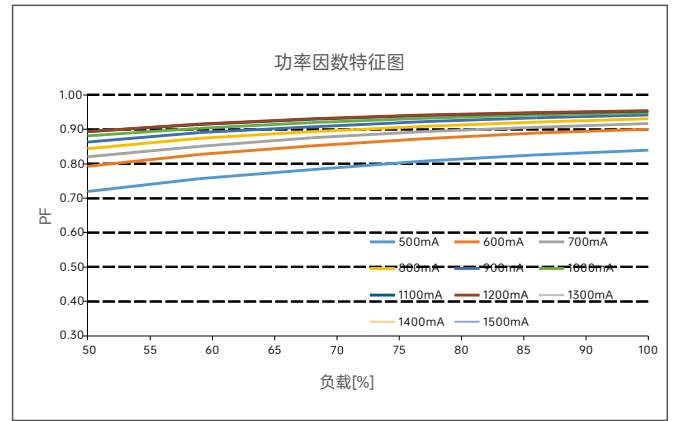
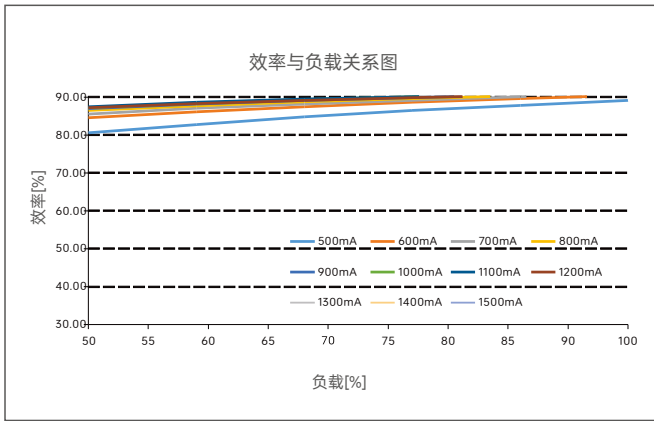

浪涌电流&对应的微型断路器(MCB)下挂载的数量对应表

微型断路器型号	B10	B13	B16	B20	B25	C10	C13	C16	C20	C25	D10	D13	D16	D20	D25
最大带载数量	15	19	24	30	40	17	22	27	35	43	20	25	31	39	49

备注:

1. 本数据测试条件: 冷启动18A(在50%Ipeak下测twidth=123us)@230V~;
2. 对于不同品牌和型号的微型断路器, 驱动器的数量会有所不同;
3. 现场安装时建议不要超过上述数量, 具体负载量以现场安装为准;
4. 当微型断路器的安装环境温度超过30°C或多个微型断路器并排安装时, 安装的驱动器数量将减少, 这需要重新计算;
5. 电工通常考虑将B型MCB用于家用照明, 将C型MCB用于商业照明;
6. 不同仪器设备测试出来的电流峰值和脉冲宽度有差异, 请使用专业仪器设备测试;

频闪测试表

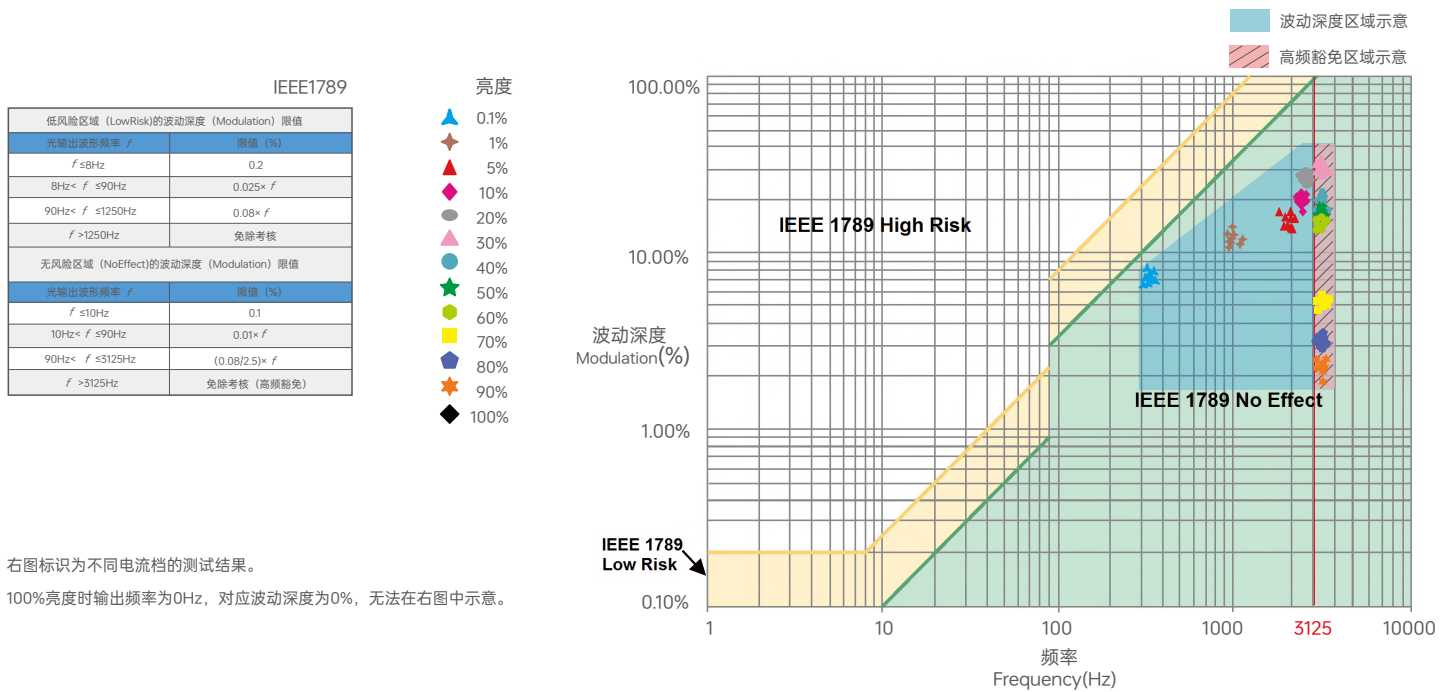

包装规格

型号	LF-60-500-1500-G1A2
包装箱尺寸	325×255×140mm(L×W×H)

包装样式图

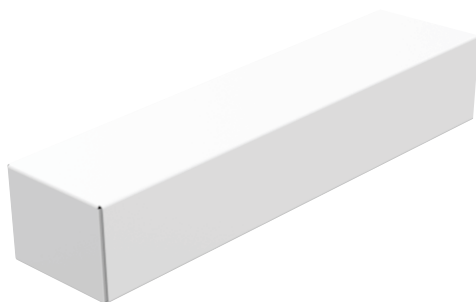

内包装盒



整箱包装

运输和贮存

1.运输

产品适用车、船、飞机交通运输工具运输。

在运输中，应使用遮篷进行防雨和防晒，并保持文明装卸，不应有剧烈振动、撞击等。

2.贮存

贮存符合类环境的规定。贮存期限超过6个月的产品建议重新检验，合格后方可使用。

注意事项

- 本产品本产品请由具有专业资格的人员进行调试安装；
- 本产品(专有型号除外)不能防水，需避免日晒雨淋。如安装在户外，请使用防水箱；
- 良好的散热条件会延长产品的使用寿命，请把产品安装在通风良好的环境；
- 安装时，避免靠近大面积金属物体，或堆叠摆放，以免信号干扰影响使用；
- 避免安装在雷区、强磁场和高压区域；
- 请检查使用的工作电压是否符合产品的参数要求；
- 通电调试前，确保所有接线正确且牢固，以免短路损坏部件，触发事故；
- 如果发生故障，请勿私自维修；如有疑问，请联系供应商。

* 本说明书的内容如有变更，恕不另行通知。若内容与您使用的功能有所不同，则以实物为准。如有疑问，欢迎向我司授权的经销商咨询。

保修条例

- 自出厂之日起保修服务期为5年。
- 在保修服务期内出现产品质量问题雷特将给予免费修理或更换服务。

无保修条例:

属下列情况不在免费保修或更换服务范围之内:

- 已经超出保修服务期;
- 过高电压、超负载、操作不当等行为造成的损坏;
- 产品外形严重损坏或变形;
- 自然灾害以及人力不可抗拒原因造成的损坏;
- 产品保修标签和产品唯一条形码损坏;
- 无雷特签订的合同或发票凭证。

1.修理或更换是雷特对客户的一补救措施。雷特不承担任何附带引起的损害赔偿,除非在适用法律范围之内。

2.雷特享有修正或调整本保修条款的权利,并以书面形式发布为准。

更新日志

版本	更改日期	更改内容	更改人
A0	20250221	正稿	黎海鹏