

Intelligent LED Driver (Constant Current)

- Housing made from SAMSUNG/COVESTRO's V0 flame retardant PC materials.
- Ultra small, thin and lightweight, screwless end cap.
- Change the output current, dimming mode and other parameters via the APP.
- Adjustable output current with 1mA step.
- Automatically recognize 0-10V and 1-10V input signal.
- Ultra-low consumption of 0-10V ports < 0.05mA.
- Soft-on and fade-in dimming function enhances your visual comfort.
- T-PWM™ super deep dimming technology, 0.01% dimming depth.
- The whole dimming process is flicker-free with high frequency exemption level.
- Comply with the EU's ErP Directive, networked standby<0.5W.
- When there is no load, the output will be 0V to prevent damage to LEDs due to poor contact.
- Overheat, over voltage, overload, short circuit protection and automatic recovery.
- Suitable for Class I / II / III indoor light fixtures.
- Normal service life can reach 100,000 hours.
- 5-year warranty (Rubycon capacitor).

4 in 1 dimming
0-10V
1-10V
10V PWM
RX



T-PWM
Dimming Technology

Flicker Free
IEEE 1789

Dimmable:
■■■■■■■■■■
1: 10000

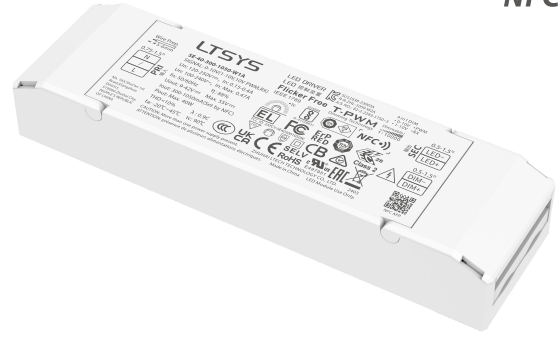

The certification icon represents undergoing certification applications only, and final certification qualification subject to actual product.



Technical Specs

Model		SE-40-300-1050-W1A	SE-30-200-800-W1A	
Features	Output Type	Constant current		
	Dimming Interface	0-10V [1-10V, 10V PWM, RX]		
	Output Feature	Isolation		
	Protection Grade	IP20		
OUTPUT	Insulation Grade	Class II (Suitable for class I / II / III light fixtures)		
	Output Voltage	9-42Vdc		
	Maximum output voltage	≤55Vdc		
	Output Current Range	300-1050mA	200-800mA	
	Output Power Range	2.7W-40W	1.8W-30W	
	Dimming Range	0-100%, down to 0.01%		
	LF Current Ripple	<3%(Maximum current for non dimming state)		
	Current Accuracy	±5%		
INPUT	PWM Frequency	≤3600Hz		
	DC Voltage Range	120-250Vdc		
	AC Voltage Range	100-240Vac		
	EoFi	100%		
	Input Voltage	115Vac/230Vac		
	Frequency	50/60Hz		
	Input Current	≤0.45A/115Vac, ≤0.22A/230Vac	≤0.34A/115Vac, ≤0.17A/230Vac	
	Power Factor	PF>0.95/115Vac (at full load), PF>0.9C/230Vac (at full load)		
	THD	THD≤10%/230Vac, at full load		
	Efficiency (Typ.)	88%	87%	
	Inrush Current	Cold start 25A[Test twidth=130us tested under 50% Ipeak]/230Vac		
	Anti Surge	L-N: 2KV		
ENVIRONMENT	Leakage Current	Max. 0.5mA		
	Working Temperature	ta: -20 ~ 45°C tc: 90°C		
	Working Humidity	20 ~ 95%RH, non-condensing		
	Storage Temperature/Humidity	-40 ~ 80°C/10-95%RH		
	Temperature Coefficient	±0.03%/°C(0-50°C)		
PROTECTION	Vibration	10-500Hz, 2G 12min/1cycle, 72 min for X, Y and Z axes respectively		
	Overload Protection	Automatically protect the device when the load exceeds 102% of the rated power. Automatically recover once load is reduced		
	Overheat Protection	Intelligently adjust or turn off the current output if the PCB temperature ≥110°C. When the PCB temperature <90°C, automatically recover normal output		
	Overvoltage Protection	Automatically protect the device when voltage exceeds the no-load voltage. It can be recovered automatically		
SAFETY & EMC	Short Circuit Protection	Enter hiccup mode if short circuit occurs, and recover automatically		
	Safety Standards	Withstand Voltage	I/P-O/P: 3750Vac	
		Insulation Resistance	I/P-O/P: 100MΩ/500VDC/25°C/70%RH	
	EMC Emission	CCC	China	GB19510.1, GB19510.14
		TUV	Germany	EN61347-1, EN61347-2-13, EN62493
		CB	CB Member States	IEC61347-1, IEC61347-2-13
		CE	European Union	EN61347-1, EN61347-2-13, EN62384
		KC	Korea	KC61347-1, KC61347-2-13
		EAC	Russia	IEC61347-1, IEC61347-2-13
		RCM	Australia	AS 61347-1, AS 61347-2-13
		ENEC	Europe	EN61347-1, EN61347-2-13, EN62384
		UKCA	Britain	BS EN 61347-1, BS EN 61347-2-13, BS EN 62493
		BIS	India	IS 15885 (PART 2/SEC 13)
	EMC Immunity	CUL	Canada	CSA C22.2 NO.250.13
		UL	America	UL 8750
CCC		China	GB/T17743, GB17625.1	
CE		European Union	EN55015, EN61000-3-2, EN61000-3-3, EN61547	
KC		Korea	KSC 9815, KSC 9547	
ErP	EAC	Russia	IEC62493, IEC61547, EH55015	
	RCM	Australia	EN55015, EN61000-3-2, EN61000-3-3, EN61547	
	UKCA	Britain	BS EN IEC 55015, BS EN IEC 61000-3-2, BS EN 61000-3-3, BS EN 61547	
	CUL	Canada	ICES-005	
OTHERS	UL	America	FCC PART 15B	
	EMC Immunity	EN61000-4-2,3,4,5,6,8,11, EN61547		
ErP	Power Consumption	Networked standby	<0.5W (After shutdown by command)	
		No-load power consumption	<0.5W (When the lamp is not connected)	
	Flicker/Stroboscopic Effect	IEEE 1789	Meet IEEE 1789 standard/High frequency exemption level	
		CIE SVM	Pst LM≤1.0, SVM≤0.4	
OTHERS	DF	Phase factor	DF≥0.9	
	Weight(N.W.)	170g±10g	150g±10g	
	Dimensions	142×40×23mm(L×W×H)		

Product Size

Unit: mm

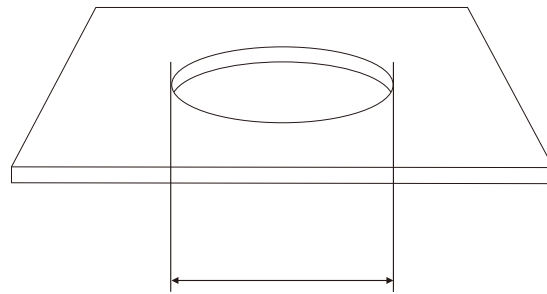
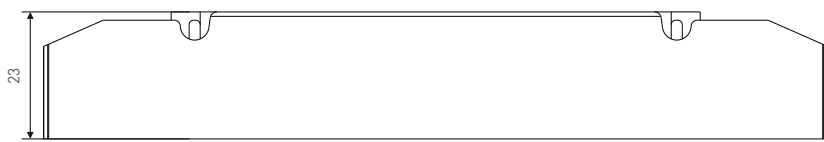
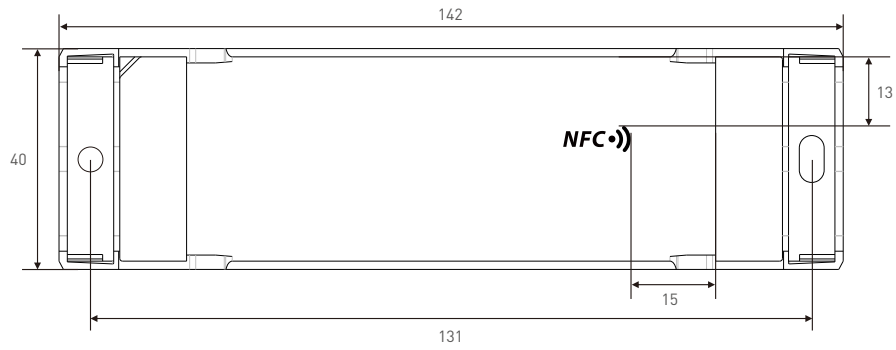

Minimum hole size: $\varnothing 48\text{mm}$ (1,89")

Wiring Diagram

0-10V Connection

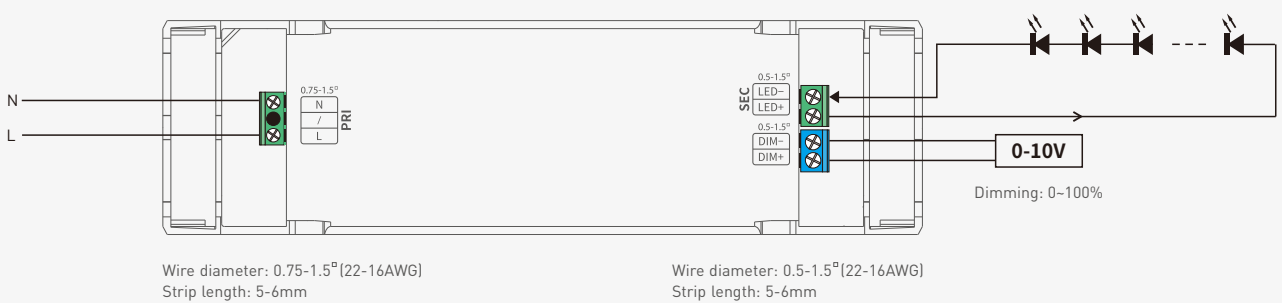

Table of Typical Corresponding Parameters for Current

The typical 16 current data sets below are for reference when selecting LED fixture models. More current levels can be set by NFC using mobile APP with 300-1050mA adjustable in 1mA step

SE-40-300-1050-W1A	Output Current	300mA	350mA	400mA	450mA	500mA	550mA	600mA	650mA	
	Output Voltage	9-42Vdc	9-42Vdc	9-42Vdc	9-42Vdc	9-42Vdc	9-42Vdc	9-42Vdc	9-42Vdc	9-42Vdc
	Output Power	2.7-12.6W	3.15-14.7W	3.6-16.8W	4.05-18.9W	4.5-21W	4.95-23.1W	5.4-25.2W	5.85-27.3W	
	Output Current	700mA	750mA	800mA	850mA	900mA	950mA	1000mA	1050mA	
	Output Voltage	9-42Vdc	9-42Vdc	9-42Vdc	9-42Vdc	9-42Vdc	9-42Vdc	9-40Vdc	9-38Vdc	
	Output Power	6.3-29.4W	6.75-31.5W	7.2-33.6W	7.65-35.7W	8.1-37.8W	8.54-39.9W	9-40W	9.45-40W	

The typical 13 current data sets below are for reference when selecting LED fixture models. More current levels can be set by NFC using mobile APP with 200-800mA adjustable in 1mA step

SE-30-200-800-W1A	Output Current	200mA	250mA	300mA	350mA	400mA	450mA	500mA	550mA	
	Output Voltage	9-42Vdc	9-42Vdc	9-42Vdc	9-42Vdc	9-42Vdc	9-42Vdc	9-42Vdc	9-42Vdc	9-42Vdc
	Output Power	1.8-8.4W	2.25-10.5W	2.7-12.6W	3.15-14.7W	3.6-16.8W	4.05-18.9W	4.5-21W	4.95-23.1W	
	Output Current	600mA	650mA	700mA	750mA	800mA	/	/	/	
	Output Voltage	9-42Vdc	9-42Vdc	9-42Vdc	9-40Vdc	9-37.5Vdc	/	/	/	
	Output Power	5.4-25.2W	5.85-27.3W	6.3-29.4W	6.75-30W	7.2-30W	/	/	/	

Application Diagram of Protective Cover

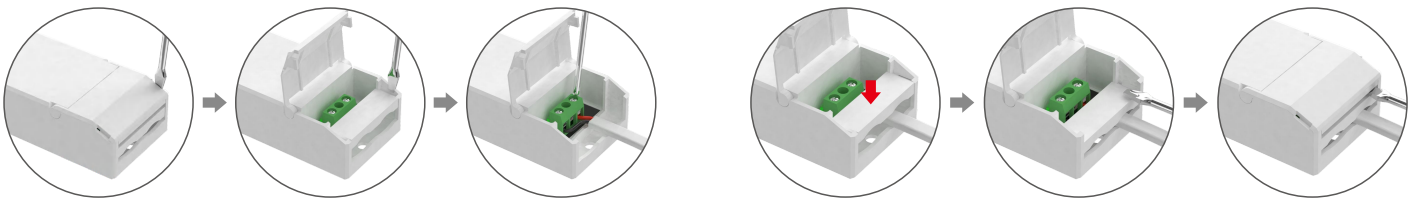

1. Put the head of a screwdriver on the side of the housing to pry up both the protective cover and wire fixing board. Then remove the wire fixing board and connect to the wires as wiring diagram shows.

2. Install the wire fixing board and press it down. Then snap on the protective cover while pressing the wire fixing board with a small flat-head screwdriver

Installation Precautions

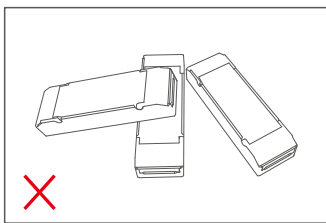

Please do not stack the products. The distance between two products should be $\geq 15\text{cm}$ so as not to affect heat dissipation and the lifespan of the products.

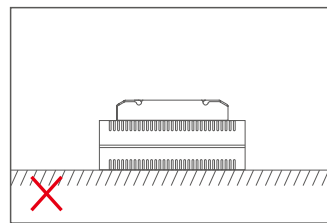
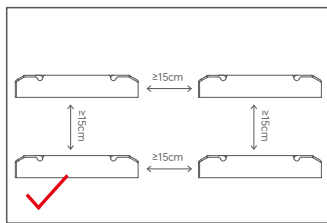

Please not place the products on LED drivers. The distance between the product and the driver should be $\geq 15\text{cm}$ so as not to affect heat dissipation and shorten the lifespan of the products.

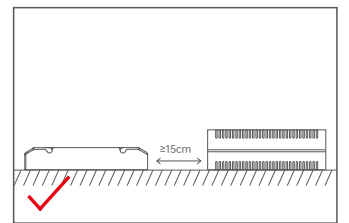

Note: The installation should be in line with the environmental operating temperature of the product. Do not install it inside the lamp to avoid exceeding the environmental operating temperature of the product, which may affect the product's lifespan.

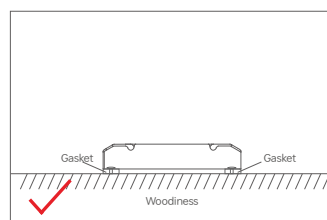
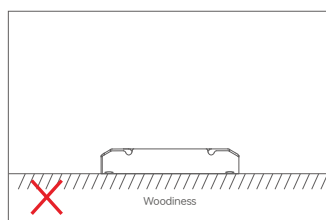

Do not fix the product screws tightly against the wooden board. Instead, add a washer with a thickness of $\geq 7\text{mm}$ under the fixing screws. Leaving some gaps can effectively dissipate heat, preventing any impact on the product's heat dissipation performance and service life.

Use the NFC Lighting APP

Scan the QR code below with your mobile phone and follow the prompts to complete the APP installation (According to performance requirements, you need to use a NFC-capable Android phone, or an iPhone 8 and later that are compatible with iOS 13 or higher).



* Before you begin setting the parameters of the driver, please make sure the driver is powered off.

Read/Write the LED driver

Use your NFC-capable phone to read LED driver data, then edit the parameters and they can be directly written to the driver.

1. Read the LED driver

On the APP home page, click **[Read/Write LED driver]**, then keep the programmer's sensing area close to the NFC logo of the driver to read the driver parameters.



2. Edit the parameters

Click **[Parameter settings]** to edit the advanced parameters, like output current, dimming mode, low power mode, etc.

3. Write to the driver

After completing the parameter settings, click **[Write]** in the upper right corner, and keep the programmer's sensing area close to the NFC logo of the driver, so the parameters can be written to the driver.

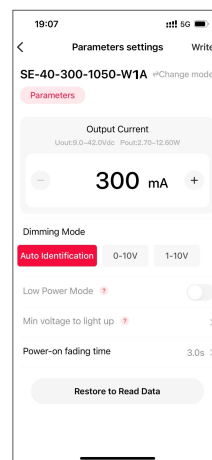
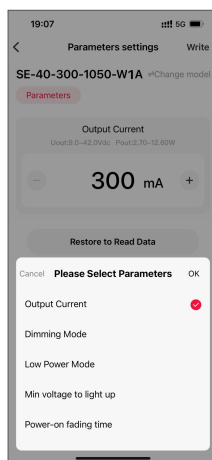
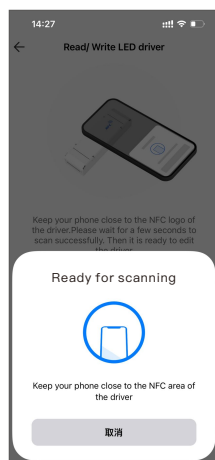
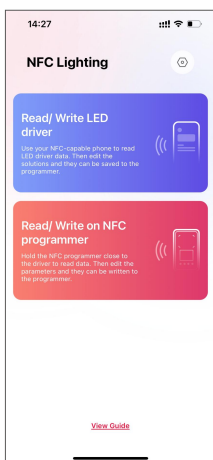

Relationship Diagrams

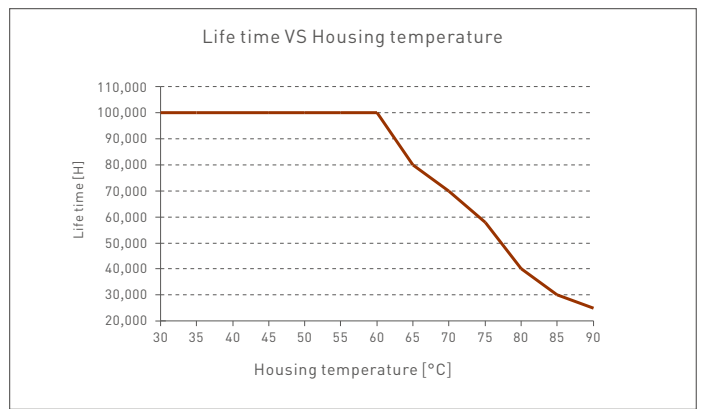
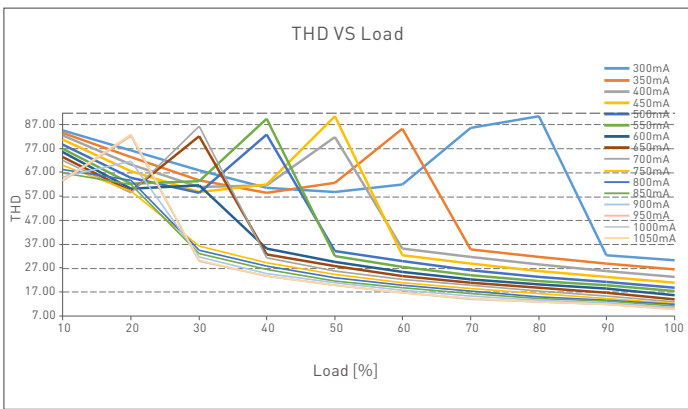
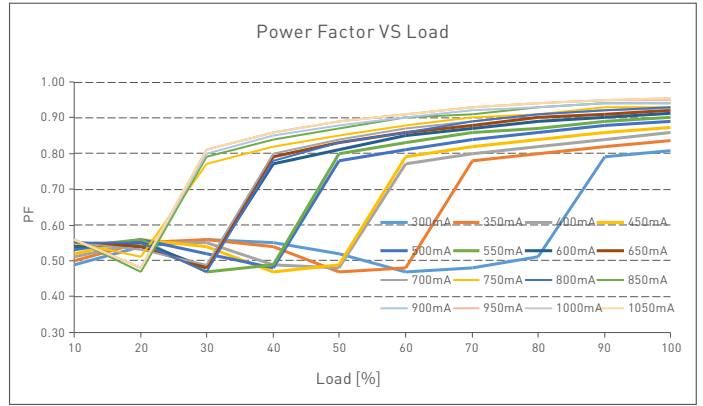
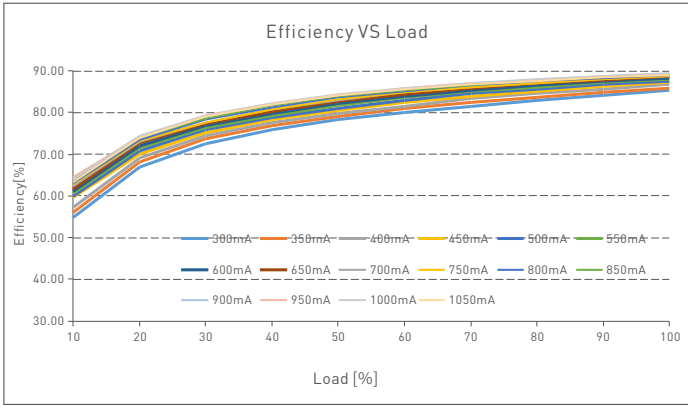

SE-40-300-1050-W1A

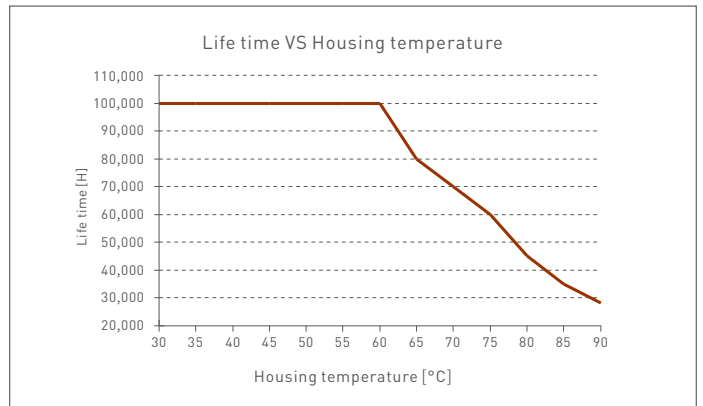
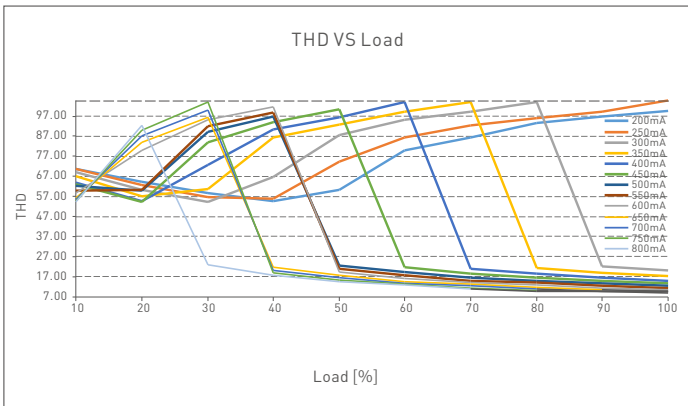
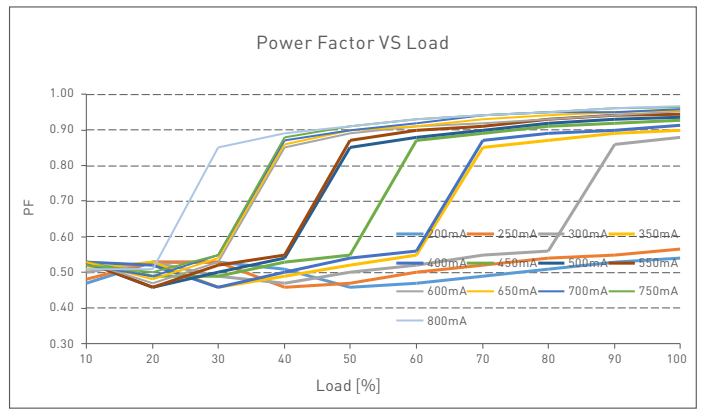
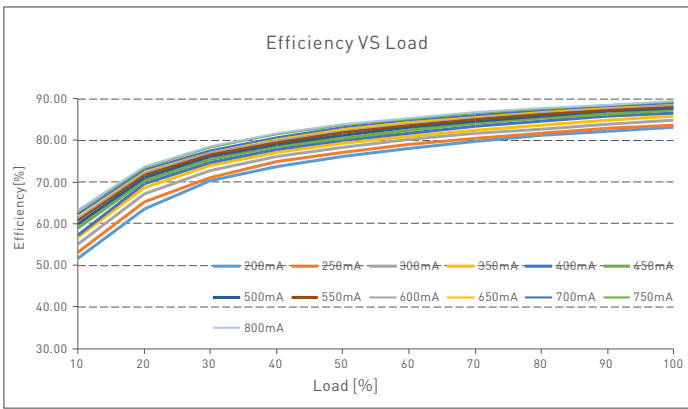

SE-30-200-800-W1A

Flicker Test Sheet

IEEE 1789

Limit of modulation in low risk area	
Waveform frequency of optical output	limit (%)
$f \leq 8\text{Hz}$	0.2
$8\text{Hz} < f \leq 90\text{Hz}$	$0.025 \times f$
$90\text{Hz} < f \leq 1250\text{Hz}$	$0.08 \times f$
$f > 1250\text{Hz}$	Exemption assessment
Limit of modulation in no effect area	
Waveform frequency of optical output	limit (%)
$f \leq 10\text{Hz}$	0.1
$10\text{Hz} < f \leq 90\text{Hz}$	$0.01 \times f$
$90\text{Hz} < f \leq 3125\text{Hz}$	$[0.08/2.5] \times f$
$f > 3125\text{Hz}$	Exemption assessment (High frequency exemption)

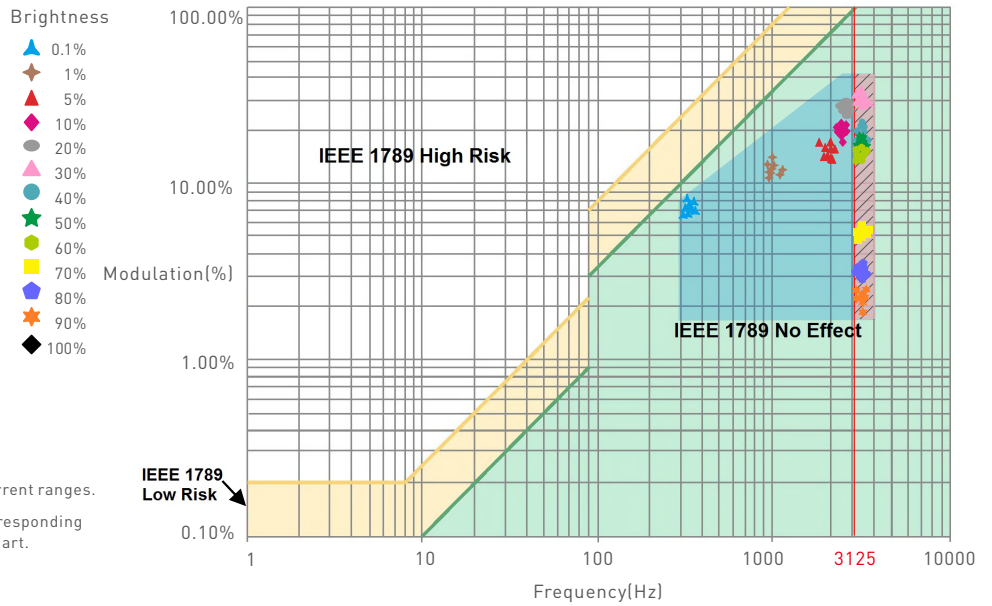

Marks in the right chart were tested results of different current ranges. The output frequency is 0Hz in 100% brightness and its corresponding modulation is 0%, which could not be shown in the right chart.

Packaging Specifications

Model	SE-40-300-1050-W1A	SE-30-200-800-W1A
Carton Dimensions	320×275×106mm(L×W×H)	320×275×106mm(L×W×H)
Quantity	20 PCS/Layer; 2 Layers/Carton; 40 PCS/Carton	20 PCS/Layer; 2 Layers/Carton; 40 PCS/Carton
Weight	0.17 kg/PC; 7.6 kg±5%/Carton	0.15 kg/PC; 6.8 kg±5%/Carton

Packaging Image

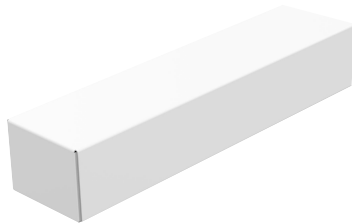

Inner Packaging Box



Carton Packaging

Transportation and Storage

1. Transportation

Products can be shipped via vehicles, boats and planes.

During transportation, products should be protected from rain and sun. Please avoid severe shock and vibration during the loading and unloading process.

2. Storage

The storage conditions should comply with the Class I Environmental Standards. The products that have been stored for more than six months are recommended to be re-inspected and can be used only after they have been qualified.

Attentions

- Products shall be installed by qualified professionals.
- LTECH products are and not lightningproof non-waterproof (special models excepted). Please avoid the sun and rain. When installed outdoors, please ensure they are mounted in a water proof enclosure or in an area equipped with lightning protection devices.
- Good heat dissipation will prolong the working life of products. Please ensure good ventilation.
- Please check if the working voltage used complies with the parameter requirements of products.
- The diameter of wire used must be able to load the light fixtures you connect and ensure the firm wiring.
- Before you power on products, please make sure all the wiring is correct in case of incorrect connection that causes damage to light fixtures.
- If a fault occurs, please do not attempt to fix products by yourself. If you have any question, please contact your suppliers.

* This manual is subject to changes without further notice. Product functions depend on the goods. Please feel free to contact our official distributors if you have any question.

Warranty Agreement

- Warranty periods from the date of delivery: 5 years.
- Free repair or replacement services for quality problems are provided within warranty periods.

Warranty exclusions below:

- Beyond warranty periods.
- Any artificial damage caused by high voltage, overload, or improper operations.
- Products with severe physical damage.
- Damage caused by natural disasters and force majeure.
- Warranty labels and barcodes have been damaged.
- No any contract signed by LTECH.

1. Repair or replacement provided is the only remedy for customers. LTECH is not liable for any incidental or consequential damage unless it is within the law.
2. LTECH has the right to amend or adjust the terms of this warranty, and release in written form shall prevail.

Update Log

Version	Updated Time	Update Content	Updated by
A0	2023.02.23	Original version	Liu Weili
A1	2025.11.01	Replace the logo;Update the laser engraving;Update the company address	Haipeng Li

LED智能调光驱动器(恒流型)

- 外壳采用科思创/三星PC阻燃V0级原料
- 超小体积、轻薄、免螺丝端盖设计
- 通过手机APP可更改输出电流、调光方式等参数，实现驱动器数据交互功能
- 电流步进值低至1mA，兼容性更高更精细
- 自动识别0-10V、1-10V输入
- 0-10V端口超低消耗<0.05mA
- 带软启动渐亮功能，让人眼视觉更舒服
- T-PWM™ 超深度调光技术，调光深度可达0.01%
- 0-100%全程调光无可视频闪，高频豁免考核级别
- 欧盟ERP空载功耗、网络待机功耗<0.5W
- 空载0V输出，防止接触不良损坏LED灯具
- 过温、过载、短路保护，可自动恢复
- 适合室内 I、II、III类灯具应用
- 常规使用下寿命可达10万小时
- 5年保修期（采用红宝石电容）

4合1调光
0-10V
1-10V
10V PWM
RX

调光

T-PWM
超深度调光技术

无频闪
IEEE 1789
高频豁免考核级别

Dimmable:
1:10000

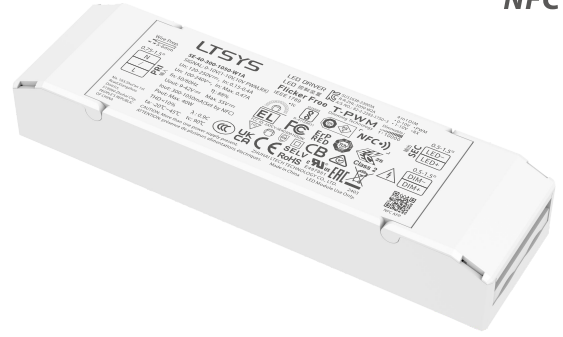

NFC



认证图标仅代表产品正在进行一系列的认证申请，认证资质以产品实物为准。



技术参数

型号	SE-40-300-1050-W1A		SE-30-200-800-W1A	
特征	输出类型	恒流		
	调光接口	0-10V (1-10V, 10V PWM, RX)		
	输出特征	隔离		
	防护等级	IP20		
输出	绝缘等级	II类 (适用于室内 I、II、III类灯具)		
	输出电压	9-42Vdc		
	最大输出电压(空载)	≤55Vdc		
	工作电流范围	300-1050mA	200-800mA	
	负载功率范围	2.7W~40W	1.8W~30W	
	调光范围	0~100%，调光深度: 0.01%		
	电流纹波	<3% (输出最大电流非调光状态)		
	电流精度	±5%		
输入	PWM频率	≤3600Hz		
	直流电压范围	120-250Vdc		
	交流电压范围	100-240Vac		
	额定电压	115Vac/230Vac		
	应急输出系数	EoF=100%		
	频率范围	50/60Hz		
	输入电流	≤0.45A/115Vac, ≤0.22A/230Vac	≤0.34A/115Vac, ≤0.17A/230Vac	
	功率因数	PF>0.95/115Vac (满载), PF>0.9C/230Vac (满载)		
	谐波THD	THD≤10%/230Vac (满载)		
	效率(Typ.)	88%@950mA (满载)	87%@750mA (满载)	
环境	浪涌电流	冷启动, 25A (在50%peak下测twidth=130us)@230Vac		
	抗浪涌	L-N: 2KV		
	漏电流	Max. 0.5mA		
	工作温度	ta: -20 ~ 45°C tc: 90°C		
保护	工作湿度	20 ~ 95%RH, 无冷凝		
	储存温度/湿度	-40 ~ 80°C/10~95%RH		
	温度系数	±0.03%/°C(0-50°C)		
	耐振动	10-500HZ, 2G 12分钟/周期, X, Y, Z轴各72分钟		
安规和电磁规格	过载保护	负载超过额定功率≥1.02倍时自动保护，减轻负载自动恢复		
	过温保护	根据PCB温度超标情况(≥110°C)，智能调节电流输出或关闭，可自动恢复；PCB温度<90°C时，可自动恢复正常输出		
	过压保护	超过空载电压值进入保护，可自行恢复		
	短路保护	输出线路短路进入打嗝模式，可自动恢复		
安规和电磁规格	耐压	输入对输出: 3750Vac		
	绝缘阻抗	输入对输出: 100MΩ/500VDC/25°C/70%RH		
	安全规范	CCC 中国	GB19510.1, GB19510.14	
		TUV 德国	EN61347-1, EN61347-2-13, EN62493	
		CB CB成员国	IEC61347-1, IEC61347-2-13	
		CE 欧盟	EN61347-1, EN61347-2-13, EN62384	
		KC 韩国	KC61347-1, KC61347-2-13	
		EAC 俄罗斯	IEC61347-1, IEC61347-2-13	
		RCM 澳洲	AS 61347-1, AS 61347-2-13	
		ENEC 欧洲	EN61347-1, EN61347-2-13, EN62384	
		UKCA 英国	BS EN 61347-1, BS EN 61347-2-13, BS EN 62493	
		BIS 印度	IS 15885 (PART 2/SEC 13)	
	CUL 加拿大	CSA C22.2 No.250.13		
	UL 美国	UL 8750		
	电磁兼容发射	CCC 中国	GB/T17743, GB17625.1	
		CE 欧盟	EN55015, EN61000-3-2, EN61000-3-3, EN61547	
		KC 韩国	KSC 9815, KSC 9547	
		EAC 俄罗斯	IEC62493, IEC61547, EH55015	
RCM 澳洲		EN55015, EN61000-3-2, EN61000-3-3, EN61547		
UKCA 英国		BS EN IEC 55015, BS EN IEC 61000-3-2, BS EN 61000-3-3, BS EN 61547		
CUL 加拿大	ICES-005			
UL 美国	FCC part 15B			
电磁兼容抗扰度	EN61000-4-2, 3, 4, 5, 6, 8, 11, EN61547			
ErP	功耗	网络待机功耗	<0.5W (通过指令开关后)	
		空载功耗	<0.5W (不接灯具时)	
	频闪/频闪效应	IEEE 1789	满足无影响/高频豁免考核级别	
		CIE SVM	Pst LM≤1.0, SVM≤0.4	
其他	DF	相位因素	DF≥0.9	
	产品重量	170g±10g	140g±10g	
	产品尺寸	142×40×23mm(L×W×H)		

尺寸图

单位: mm

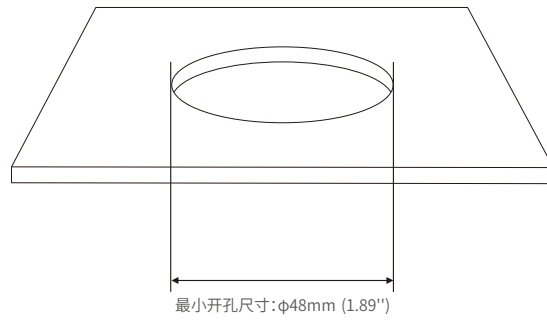
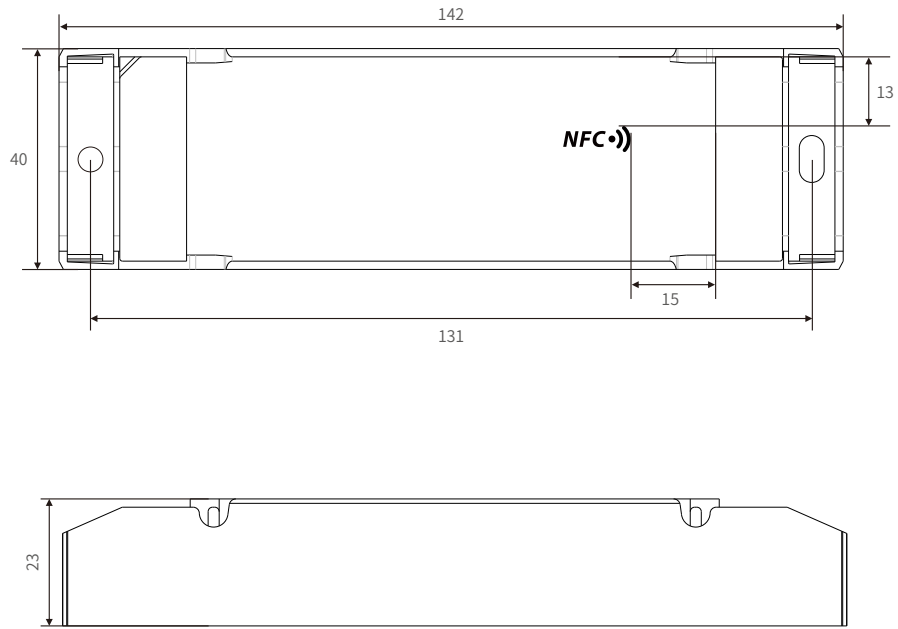

连接应用图

0-10V 连接方式

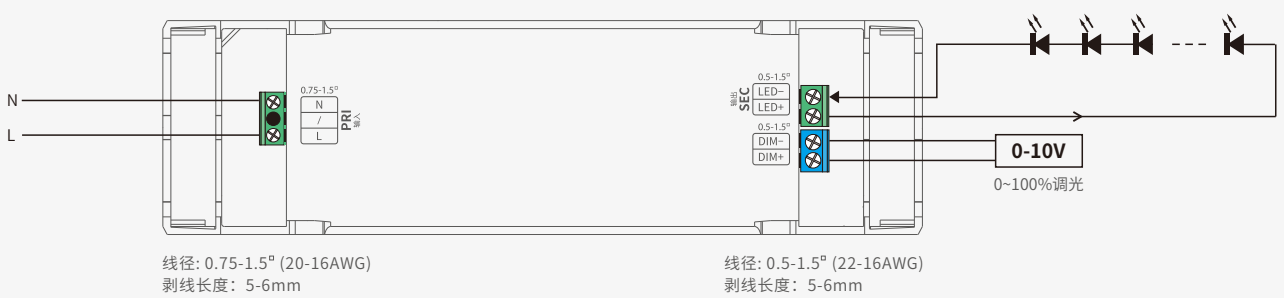

典型电流对应参数表

下图典型16组电流数据供选型参考，均可通过手机APP NFC设置更多电流，可设置范围在300-1050mA，电流步进值低至1mA

SE-40-300-1050-W1A	输出电流	300mA	350mA	400mA	450mA	500mA	550mA	600mA	650mA
	输出电压	9-42Vdc	9-42Vdc	9-42Vdc	9-42Vdc	9-42Vdc	9-42Vdc	9-42Vdc	9-42Vdc
	输出功率	2.7-12.6W	3.15-14.7W	3.6-16.8W	4.05-18.9W	4.5-21W	4.95-23.1W	5.4-25.2W	5.85-27.3W
	输出电流	700mA	750mA	800mA	850mA	900mA	950mA	1000mA	1050mA
	输出电压	9-42Vdc	9-42Vdc	9-42Vdc	9-42Vdc	9-42Vdc	9-42Vdc	9-40Vdc	9-38Vdc
	输出功率	6.3-29.4W	6.75-31.5W	7.2-33.6W	7.65-35.7W	8.1-37.8W	8.54-39.9W	9-40W	9.45-40W

下图典型13组电流数据供选型参考，均可通过手机APP NFC设置更多电流，可设置范围在200-800mA，电流步进值低至1mA

SE-30-200-800-W1A	输出电流	200mA	250mA	300mA	350mA	400mA	450mA	500mA	550mA
	输出电压	9-42Vdc	9-42Vdc	9-42Vdc	9-42Vdc	9-42Vdc	9-42Vdc	9-42Vdc	9-42Vdc
	输出功率	1.8-8.4W	2.25-10.5W	2.7-12.6W	3.15-14.7W	3.6-16.8W	4.05-18.9W	4.5-21W	4.95-23.1W
	输出电流	600mA	650mA	700mA	750mA	800mA	/	/	/
	输出电压	9-42Vdc	9-42Vdc	9-42Vdc	9-40Vdc	9-37.5Vdc	/	/	/
	输出功率	5.4-25.2W	5.85-27.3W	6.3-29.4W	6.75-30W	7.2-30W	/	/	/

保护盖应用图

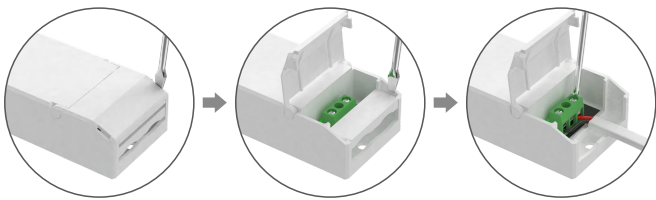

1. 在侧板处使用螺丝批撬起保护盖，并撬起压线板将其拆下后，按照接线图进行接线。

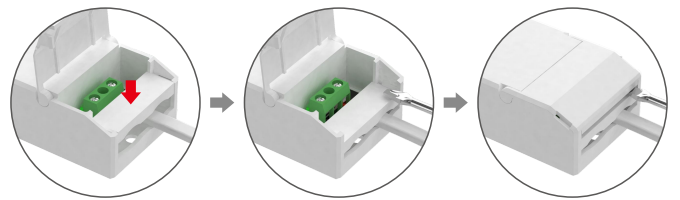

2. 装上压线板并向下按压，使用小一字螺丝批按压住压线板的同时，将保护盖向下扣合即可。

安装注意事项

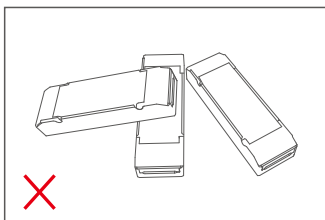

请勿将产品堆叠摆放，产品与产品间隔距离应 $\geq 15\text{cm}$ ，避免影响产品散热和使用寿命。

注：安装需符合产品的环境工作温度，切勿安装到灯具内部，以免超出产品环境工作温度影响产品寿命。

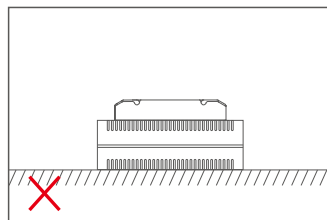
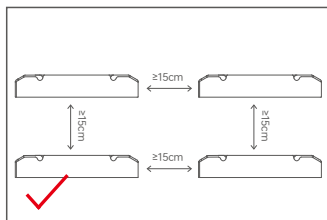

请勿将产品置于电源上方，与电源间隔距离应 $\geq 15\text{cm}$ ，避免影响产品散热而减少使用寿命。

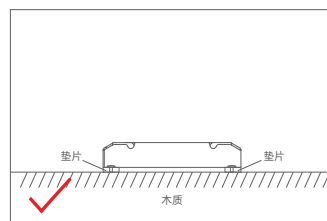
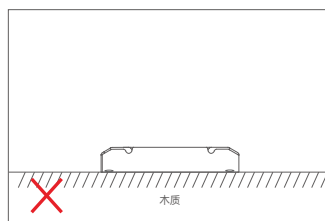
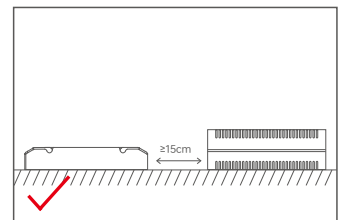

请勿将产品螺丝固定紧贴于木板，应在固定螺丝下增加 $\geq 7\text{mm}$ 的垫片，留点空隙可以有效散热，避免影响产品散热和使用寿命。

搭配 NFC Lighting APP 使用

通过手机扫描下方二维码，按提示完成APP安装。（因性能需求，要求手机型号苹果：iPhone 8及以上、且操作系统iOS13及以上； 安卓：具备NFC功能）



* 设置驱动器参数时，必须在驱动器断电情况下进行操作。

读/写智能电源

使用手机，通过NFC读取驱动器信息，根据需求设置参数后，可直接写入驱动器。

1. 读取驱动器

在APP“首页”点击【读/写智能电源】，将手机感应区域靠近驱动器NFC感应区，读取驱动器参数。



2. 编辑参数

点击【参数管理】可编辑输出电流、调光方式、通电渐变时间等更多高级参数。

3. 写入驱动器

参数设置完成后，点击右上角【写入】，将手机感应区域靠近驱动器NFC感应区，即可写入驱动器成功修改参数。



关系图表

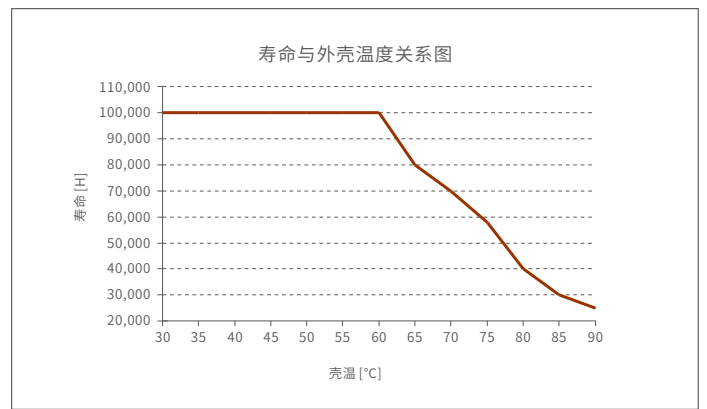
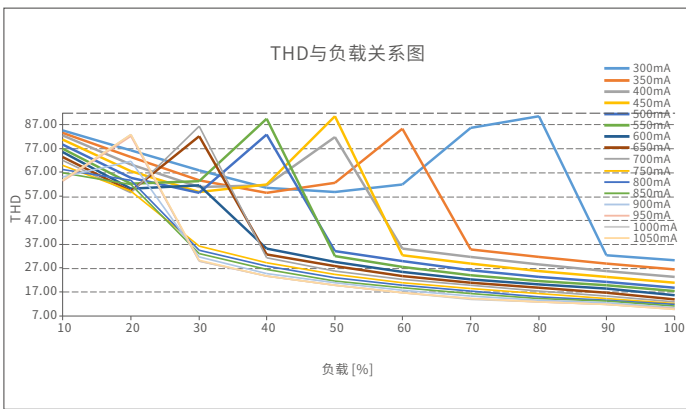
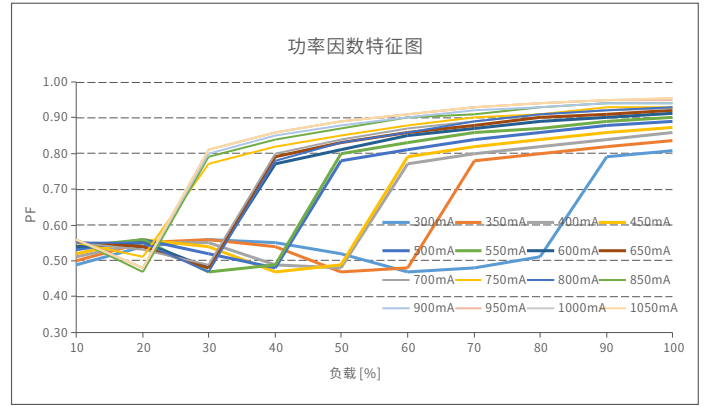
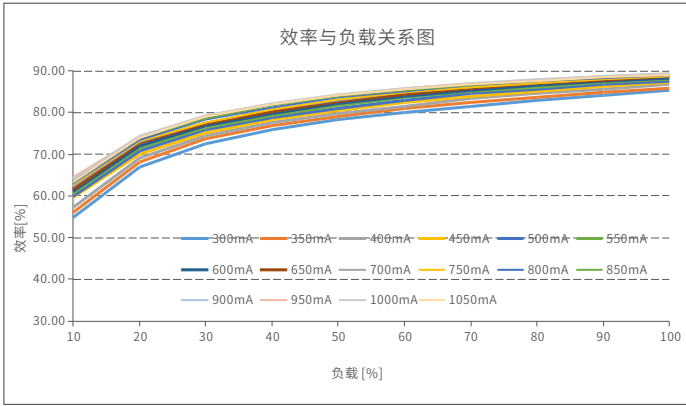

SE-40-300-1050-W1A

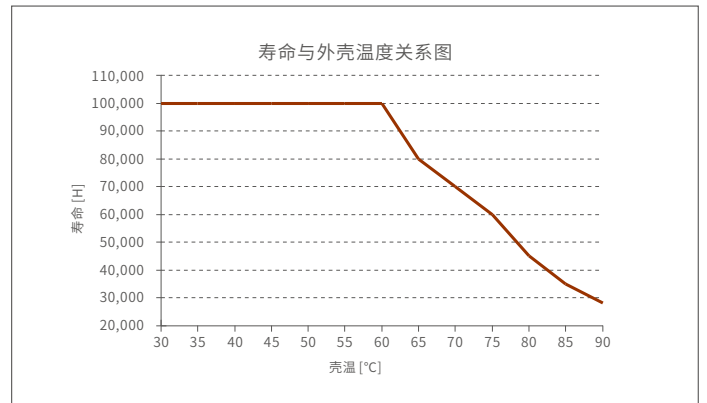
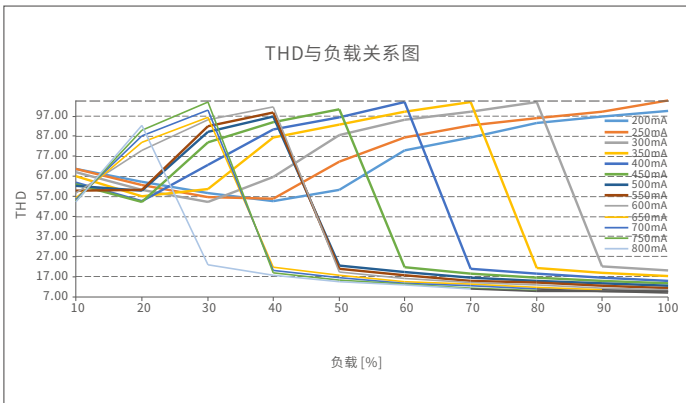
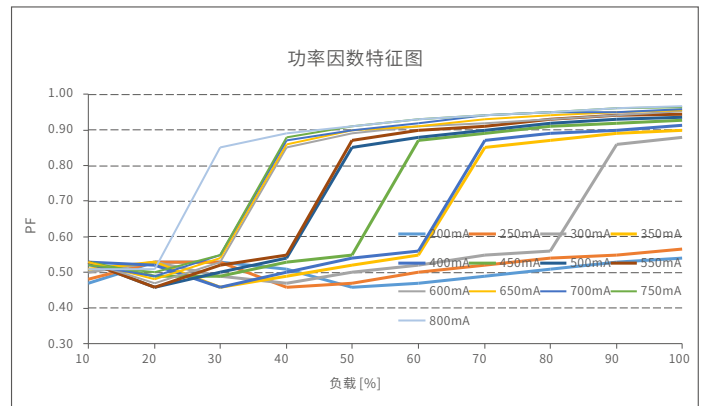
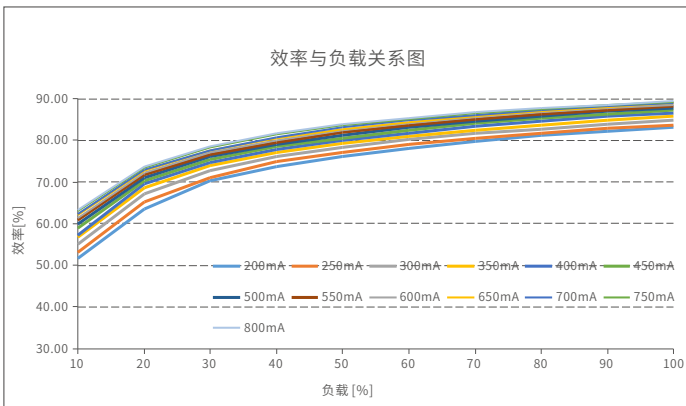

SE-30-200-800-W1A

频闪测试表

IEEE 1789

低风险区域 (Low Risk) 的波动深度 (Modulation) 限值	
光输出波形频率 f	限值 (%)
$f \leq 8\text{Hz}$	0.2
$8\text{Hz} < f \leq 90\text{Hz}$	$0.025 \times f$
$90\text{Hz} < f \leq 1250\text{Hz}$	$0.08 \times f$
$f > 1250\text{Hz}$	免除考核
无风险区域 (No Effect) 的波动深度 (Modulation) 限值	
光输出波形频率 f	限值 (%)
$f \leq 10\text{Hz}$	0.1
$10\text{Hz} < f \leq 90\text{Hz}$	$0.01 \times f$
$90\text{Hz} < f \leq 3125\text{Hz}$	$(0.08/2.5) \times f$
$f > 3125\text{Hz}$	免除考核 (高频豁免)

- 亮度
- ▲ 0.1%
 - ◆ 1%
 - ▲ 5%
 - ◆ 10%
 - 20%
 - 30%
 - 40%
 - ★ 50%
 - 60%
 - 70%
 - 80%
 - ★ 90%
 - ◆ 100%

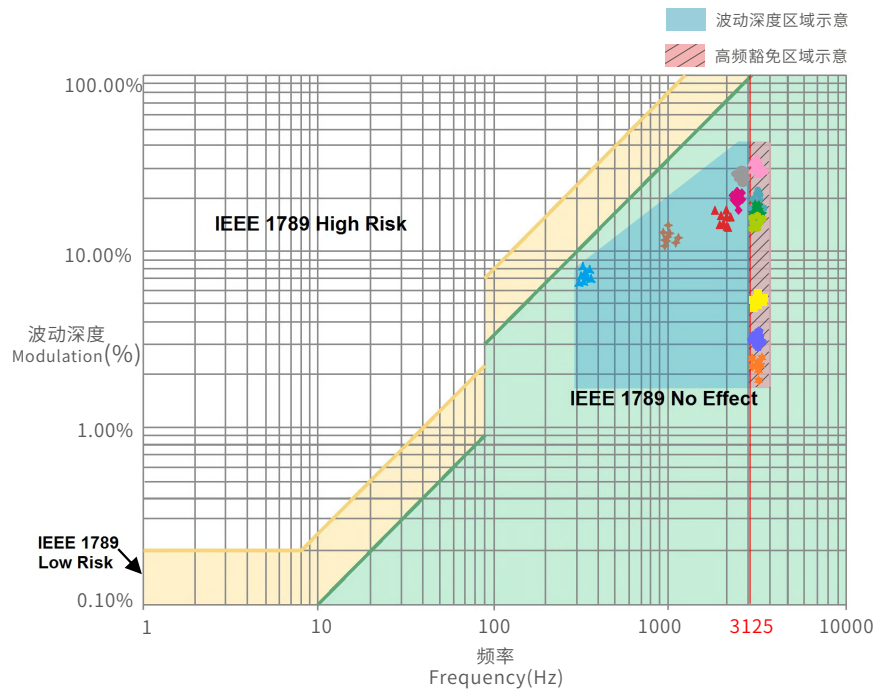

右图标识为不同电流档的测试结果。
100%亮度时输出频率为0Hz，对应波动深度为0%，无法在右图中示意。

包装规格

型号	SE-40-300-1050-W1A	SE-30-200-800-W1A
包装箱尺寸	320×275×106mm(L×W×H)	320×275×106mm(L×W×H)
数量	20PCS/层; 2层/箱; 40PCS/箱	20PCS/层; 2层/箱; 40PCS/箱
重量	0.17kg/PC; 7.6kg±5%/箱	0.15kg/PC; 6.8kg±5%/箱

包装样式图

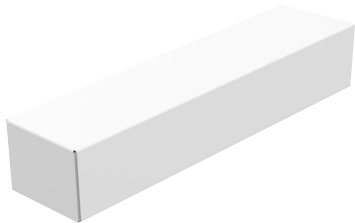

内包装盒



整箱包装

运输和贮存

1. 运输

产品适用车、船、飞机交通运输工具运输。

在运输中，应使用遮蓬进行防雨和防晒，并保持文明装卸，不应有剧烈振动、撞击等。

2. 贮存

贮存符合I类环境的规定。贮存期限超过6个月的产品建议重新检验，合格后方可使用。

注意事项

- 请由具有专业资格的人员进行调试安装；
- 雷特产品（专有型号除外）不能防水防雷，需避免日晒雨淋，如安装在户外，请用防水箱和防雷装置；
- 良好的散热条件会延长产品的使用寿命，请把产品安装在通风良好的环境；
- 请检查使用的工作电压是否符合产品的参数要求；
- 使用的电线直径大小必须能够负载连接的LED灯具，并确保接线牢固；
- 通电调试前，应确保所有接线正确，避免因接线错误而导致灯具损坏；
- 如果发生故障，请勿私自维修；如有疑问，请联系供应商。

* 本说明书的内容如有变更，恕不另行通知。若内容与您使用的功能有所不同，则以实物为准。如有疑问，欢迎向我司授权的经销商咨询。

保修条例

- 自出厂之日起保修服务期为5年。
- 在保修服务期内出现产品质量问题雷特将给予免费修理或更换服务。

非保修条例:

属下列情况不在免费保修或更换服务范围之内:

- 已经超出保修服务期;
- 过高电压、超负载、操作不当等人为造成的损坏;
- 产品外形严重损坏或变形;
- 自然灾害以及人力不可抗拒原因造成的损坏;
- 产品保修标签和产品唯一条形码损坏;
- 无雷特签订的合同或发票凭证。

1. 修理或更换是雷特对客户唯一补救措施。雷特不承担任何附带引起的损害赔偿，除非在适用法律范围之内。
2. 雷特享有修正或调整本保修条款的权利，并以书面形式发布为准。

更新日志

版本	更改日期	更改内容	更改人
A0	2022.10.09	正稿	刘伟丽
A1	2025.11.01	更换logo; 更新镭雕; 更新公司地址	黎海鹏