

Xiaolei

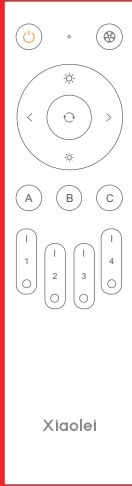

LED BLE Remote Control

R8

Manual
www.xiaolei.com.cn

Product Introduction

- Bluetooth 5.2 SIG Mesh communication protocol, featuring strong networking capability and reliable and stable local control;
- When paired with Bluetooth lamps, it can realize control over light switching, dimming, and color adjustment;
- When paired with curtains, it can realize control over curtain opening/closing, adjustment of opening/closing percentage, and rotation of curtain blades;
- When paired with a smart gateway, it can support local automation/cloud automation control modes;
- Supports local scenes, allowing control without a gateway even when the network is disconnected, which is faster and more stable;
- Supports power detection. When the remote control's power is too low, the indicator light will flash to remind you to replace the battery;
- Equipped with a dedicated wall-mount base, it can be flexibly used on the wall or desktop to meet diverse usage needs;
- OTA upgrade is supported.

Specification Parameters

Model	R8
Control Type	DIM/CT/RGB/RGBW/RGBCW/Curtain
Working Voltage	3Vdc (1×CR2032 button battery)
Wireless Type	Bluetooth 5.2 SIG Mesh
Number of Zones	4-zone control
Compatible Driver	B5-3A, BLE driver and BLE controller
Working Temperature	-20°C~55°C
Dimensions	40×150×13mm(L×W×H)
Package Size	46×155×19mm(L×W×H)
Product Weight	85g

Product Size Unit:mm

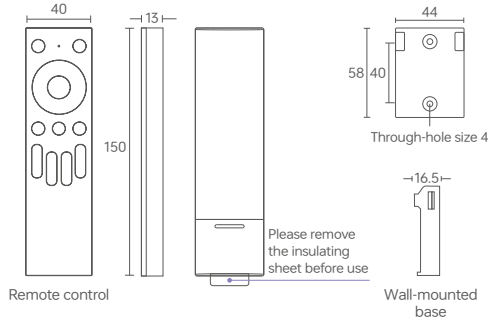

Application Schematic Diagram

① The remote control is used in conjunction with the wireless driver.

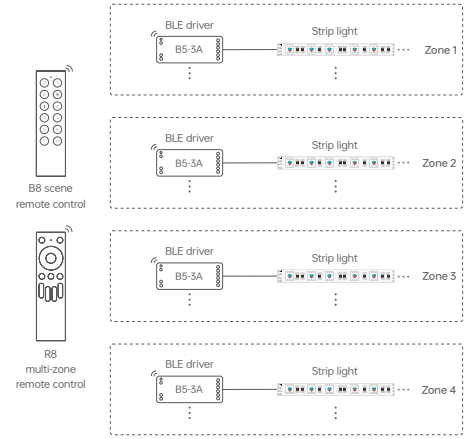

② The remote control is used with the curtain.

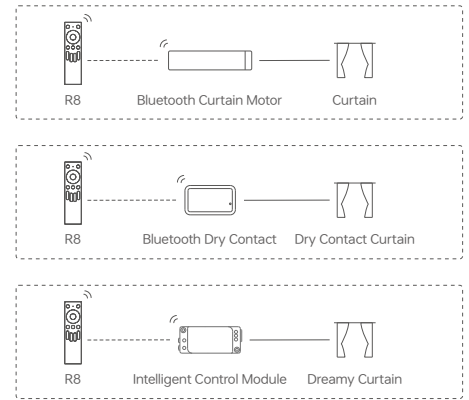

Remote Control Button Functions

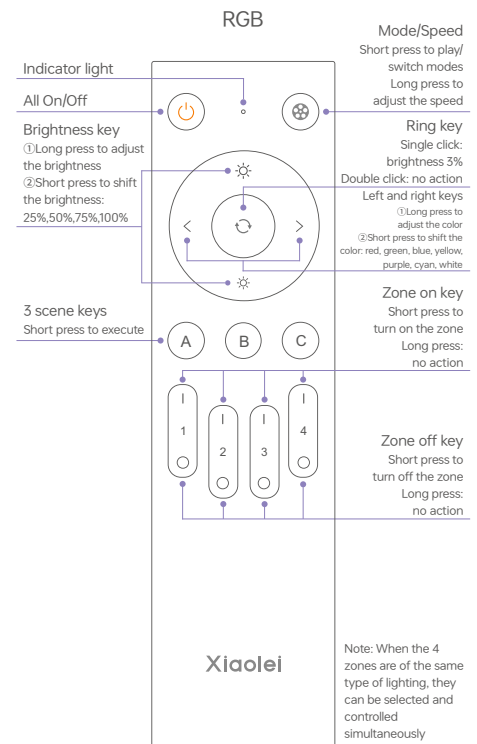
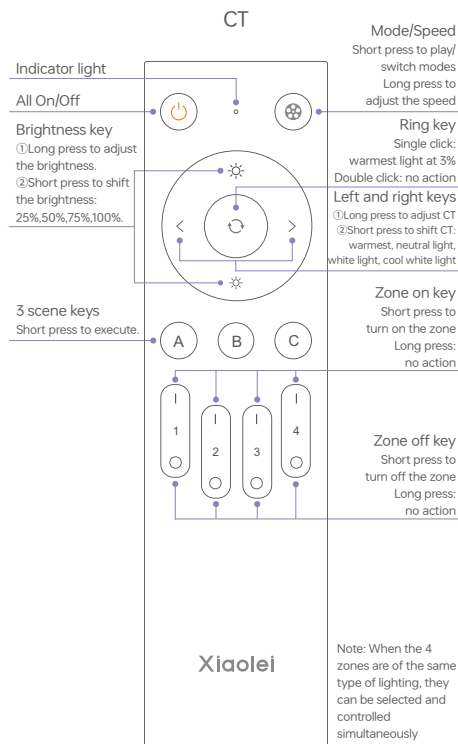
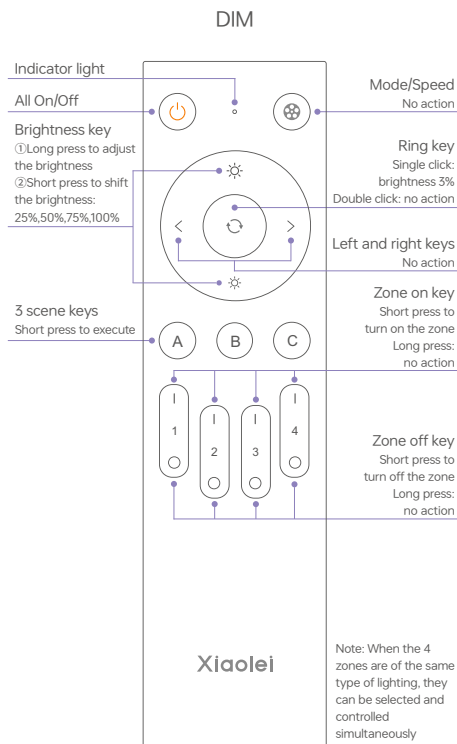

RGBW

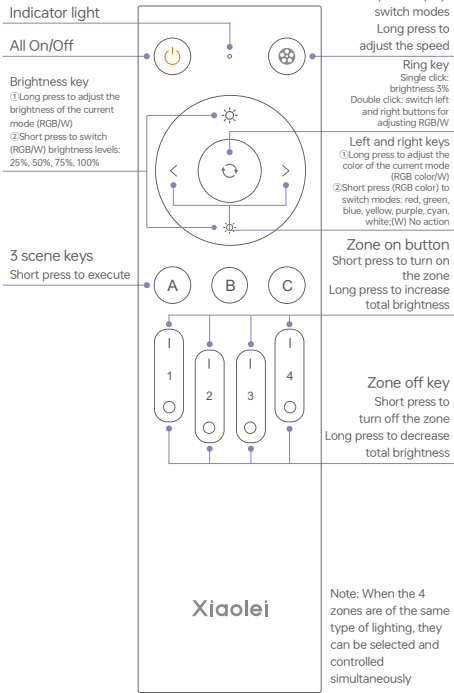

RGBCW

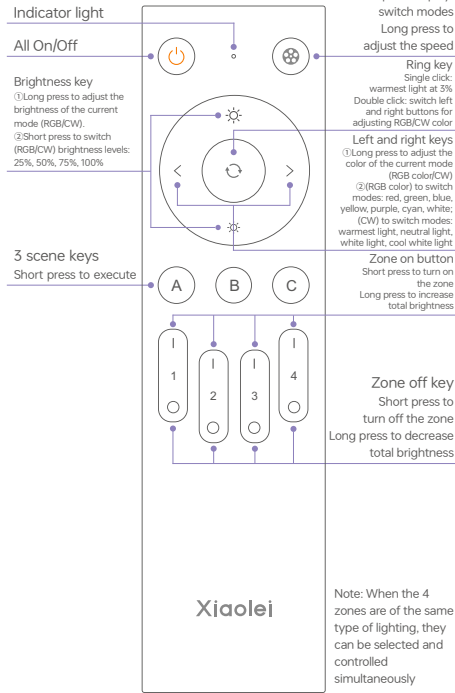

SPI

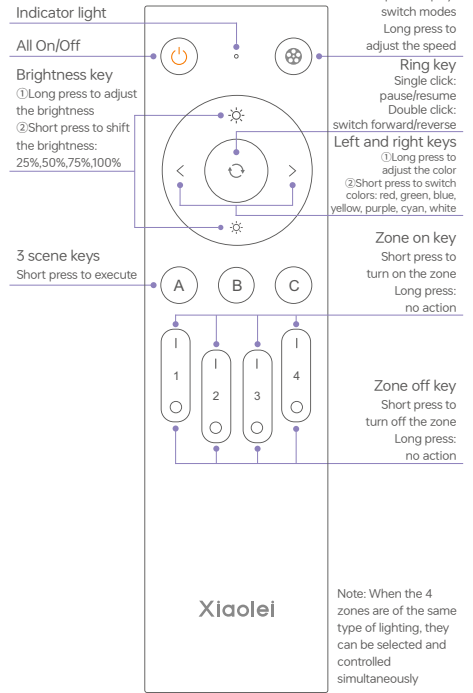

Switch module

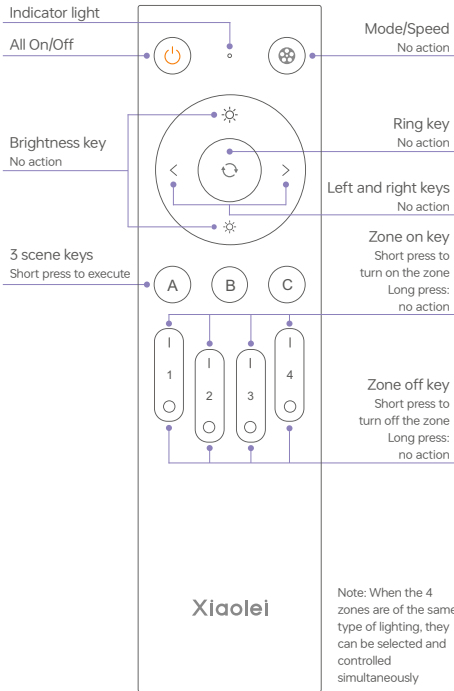

Bluetooth curtain

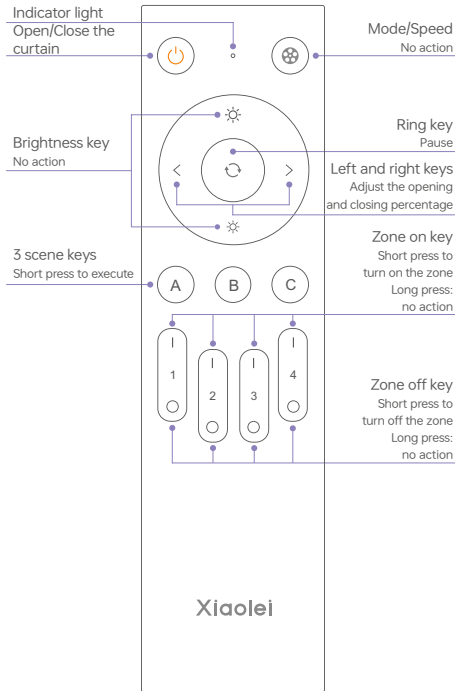

Dry contact curtain

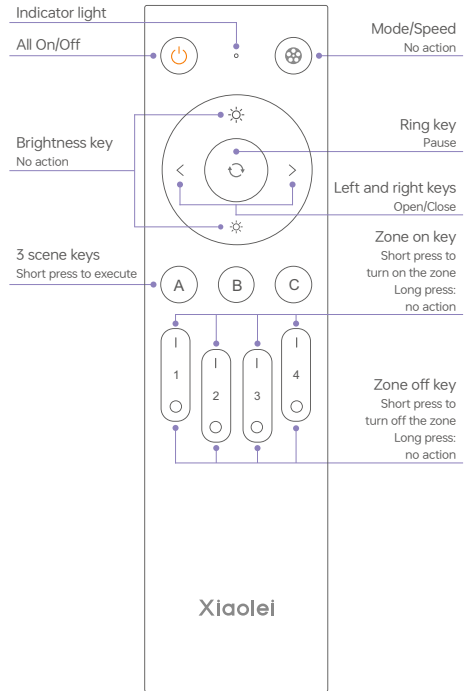

Dry contact dreamy curtain

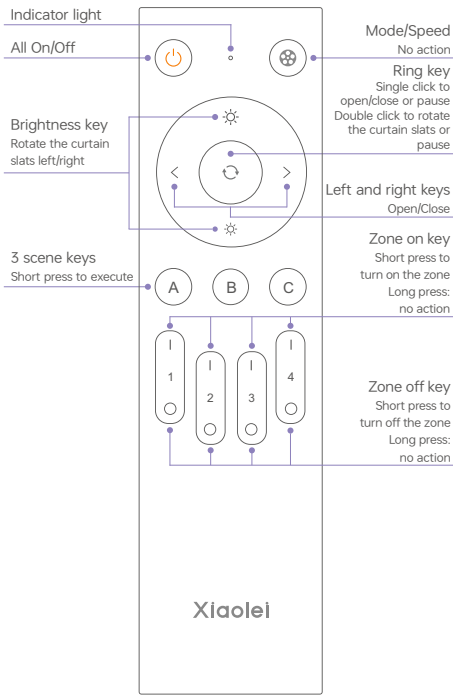

1. Single-click the zone on/off key: Turn on/off the current zone. Zone binding must be done via the L-Home APP.
2. If a zone is selected and the on key of another zone is pressed within 3 seconds, the two zones will be selected in an overlapping manner, and you can control the selected zones simultaneously at this time.
3. If the same zone is selected repeatedly within 3 seconds, only this zone will remain selected (for example: if zones 1 and 2 are already selected, and the on key of zone 2 is pressed again within 3s, only zone 2 will be selected).

Multiple Types of Groups Cannot be Selected for Simultaneous Control

Select light groups and curtain groups simultaneously

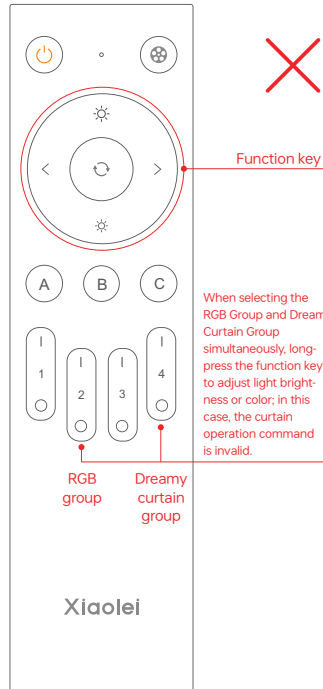

When selecting the RGB Group and Dream Curtain group simultaneously, long-press the function key to adjust light brightness or color; in this case, the curtain operation command is invalid.

Select different types of light groups simultaneously

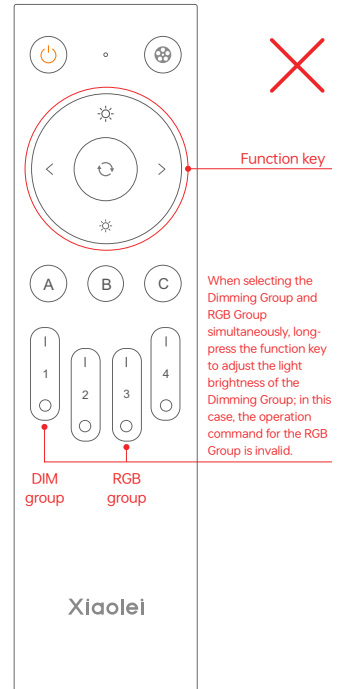

When selecting the Dimming Group and RGB Group simultaneously, long-press the function key to adjust the light brightness of the Dimming Group; in this case, the operation command for the RGB Group is invalid.

Note: The operation of function keys varies depending on the selected group type. Therefore, you need to first select the group you want to control before operating the function keys. Additionally, you must select lamp groups of the same type simultaneously to control them together.

APP Operation Instructions

1. Account Registration

Scan the QR code below with your mobile phone. After completing the APP installation as prompted, you can log in or register.



L-Home APP

2. Network Configuration Operation

After creating a home on the L-Home APP, new users should click the "+" icon in the upper-right corner of the [Rooms] interface to add a device. In the device addition list, select "Smart Light," and then complete the addition as prompted by the installation interface.

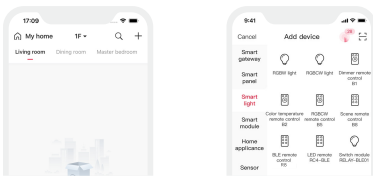

3. Binding Scenes/Zones

On the "Room" interface, click the added remote control to enter the [Control] interface.

Binding a scene: Click the "..." in "Bind scene", select to bind "Local Scenes/DALI Scenes", and after successful saving, you can execute the scenes by short-pressing the scene keys on the physical remote control.

Binding a zone: Click the "..." in "Bind zones", select to bind the device, and after saving, you can control the device via the physical remote control.



4. Automation

Ensure that a smart gateway has been added to the home, such as the Super Panel 12S. Select "Automation" in the [Intelligence] interface, and click the "+" icon to create an automation. You can choose the local/cloud execution method, and set the triggering conditions and execution actions. When the set triggering conditions are met, a series of device actions will be automatically triggered to achieve remote linkage.

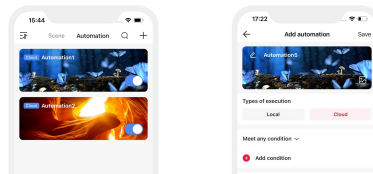

by pressing [Restore Factory Settings].

- ② The device has not been activated. To activate it, you can perform the operation by pressing [Activate Remote Control].
- ③ The insulating sheet has not been pulled out, or the battery is dead.

Attentions

- Product installation and commissioning should be done by a qualified professional.
- LTECH products are and not lightningproof non-waterproof (special models excepted). Please avoid the sun and rain. When installed outdoors, please ensure they are mounted in a water proof enclosure or in an area equipped with lightning protection devices.
- Good heat dissipation will prolong the working life of products. Please ensure good ventilation.
- Please check if the working voltage used complies with the parameter requirements of products.
- The diameter of wire used must be able to load the light fixtures you connect and ensure the firm wiring.
- Before you power on products, please make sure all the wiring is correct.
- If a fault occurs, please do not attempt to fix products by yourself. If you have any question, please contact your suppliers.

Warranty Agreement

- Warranty periods from the date of manufacture: 2 years.
- Free repair or replacement services for quality problems are provided within warranty periods.

Warranty exclusions below:

Following conditions are not within the guarantee range of free repairing or replacement services:

- Beyond warranty periods.
- Any artificial damage caused by high voltage, overload, or improper operations.
- Products with severe physical damage.
- Damage caused by natural disasters and force majeure.
- Warranty labels and barcodes have been damaged.
- No any contract or invoice signed by LTECH.

1. Repair or replacement provided is the only remedy for customers. LTECH is not liable for any incidental or consequential damage unless it is within the law.
2. LTECH has the right to amend or adjust the terms of this warranty. The warranty that issues in writing shall prevail.

* This manual is subject to changes without further notice. Product functions depend on the goods. Please feel free to contact our official distributors if you have any question.

FAQs

1. How to activate the remote control?

Press and hold the "All On/All Off" button on the remote control for 6 seconds until the indicator light flashes, indicating successful activation.

2. How to check the battery level?

Open the L-Home APP, select the "Battery Level" function on the remote control settings page, and follow the instructions to actively activate the device to obtain the current battery level information of the remote control (the battery level value will only be updated if there is a significant change). When the battery level is below 10%, the APP will receive a low battery reminder.

3. Why does the button indicator flash 5 times during operation?

It is a reminder that the battery is in a low-power state, and the device battery should be replaced in a timely manner.

4. What are the reasons for unsuccessful network access?

- ① The device has not been disconnected from the network. To disconnect it from the network, you can perform the operation